

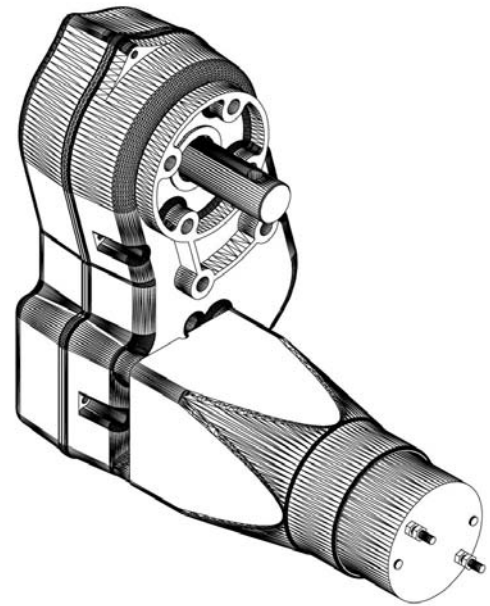

Mounting Template

Please do not fax.

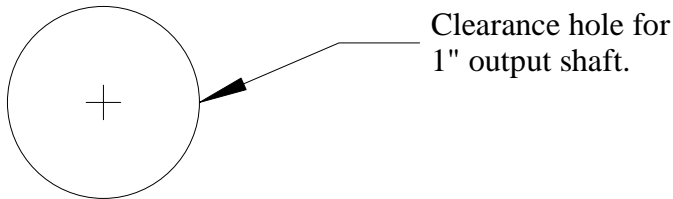
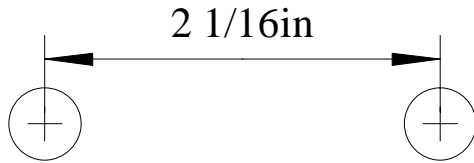

This sheet can be used as a drilling template for the six gearmotor mounting bolts.

Drill or cut a clearance hole for the 1" output shaft.

Drill six 3/8" holes for the mounting bolts. Drilling or cutting a larger hole may allow the threaded inserts to pull out if the mounting bolts are overtightened.

Use all six bolts when mounting your gearmotor!

Tighten the mounting bolts by hand only. Do not overtighten!