

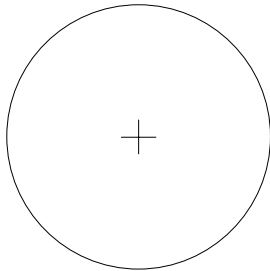

Mounting Template

Please do not fax.

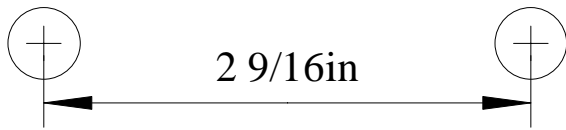

Clearance hole for
1-3/8" output hub.

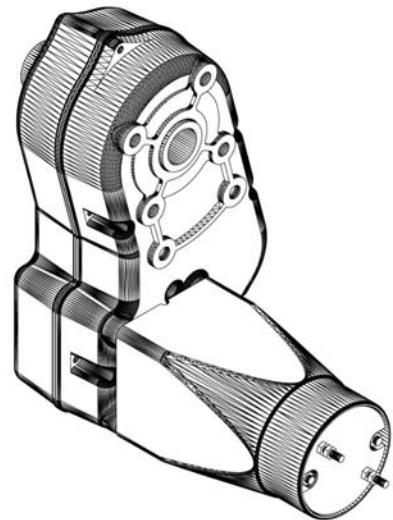

This sheet can be used as a drilling template for the six gearmotor mounting bolts.

Drill or cut a clearance hole for the 1-3/8" output hub.

Drill six 3/8" holes for the mounting bolts. Drilling or cutting a larger hole may allow the threaded inserts to pull out if the mounting bolts are overtightened.

Use all six bolts when mounting your gearmotor!

Tighten the mounting bolts by hand only. Do not overtighten!