

ATTENTION

DURING INSTALLATION, SOME FABRICATION MAY BE REQUIRED.

Document #: P/# 101501
Revised: 12/29/25 WLH



Table of Contents

Tools & Parts

Recommended Tools..... 1

Tarp Spool Kits

Tarp Spool w/ Full Head Assembly 2-3

Tarp Spool W/ Wind Deflector and Spool Only..... 4-5

Pivot Sets

External Pivots 6-7

Under Body Pivots 8-9

Kunckle Pivots..... 10-12

Bow Sets

Tarp Bow 13-14

Tension Bow 15-16

Final Adjustments..... 17

Operation Manual

Winding and Unwinding Tarp 18

Pivots and Bows / Gear Motor 19

Maintenance Manual

Maintenance intervals vary based on environmental conditions. 20



INSTALLATION INSTRUCTIONS

Front to Back - Flip Style Tarp Systems

Recommended Tools



Safety Glasses and Gloves

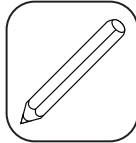

Pencil or Marker

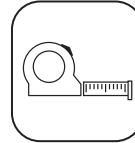

Tape Measure

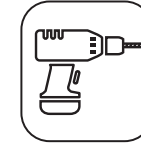

Cordless or Impact Drill

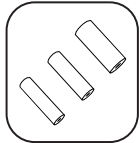

5/8", 1/2", & 9/16" Sockets

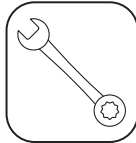

5/8", 1/2", & 9/16" Wrenches



Ratchet



Tarp Spool Kits

Note: SD kit includes 85' of wire instead of the standard 55'. Never exceed the amount of wire provided with your tarping system w/o increasing gage size.

Tarp Spool w/ Full Head Assembly

Mounting the Head Assembly

In general, the head assembly should be mounted as far forward as possible so that it will not be damaged by loaders. Read Sections 1-4 to see which best fits your situation.

Typical Installation

- a. Center the head assembly on the front of the cab guard and clamp it in place.
- b. Drill four mounting holes for the included 5/8" bolts. All holes should be centered about 1" down from the bottom of the lip of the head assembly. The 2 outside holes should be about 1.5" in from the sides of the cab guard and the 2 inside holes should be about 18" in from the outside holes.
- c. Bolt the head assembly in place using the included 5/8" x 1 1/2" bolts, nylock nuts, and washers (Fig. 1).

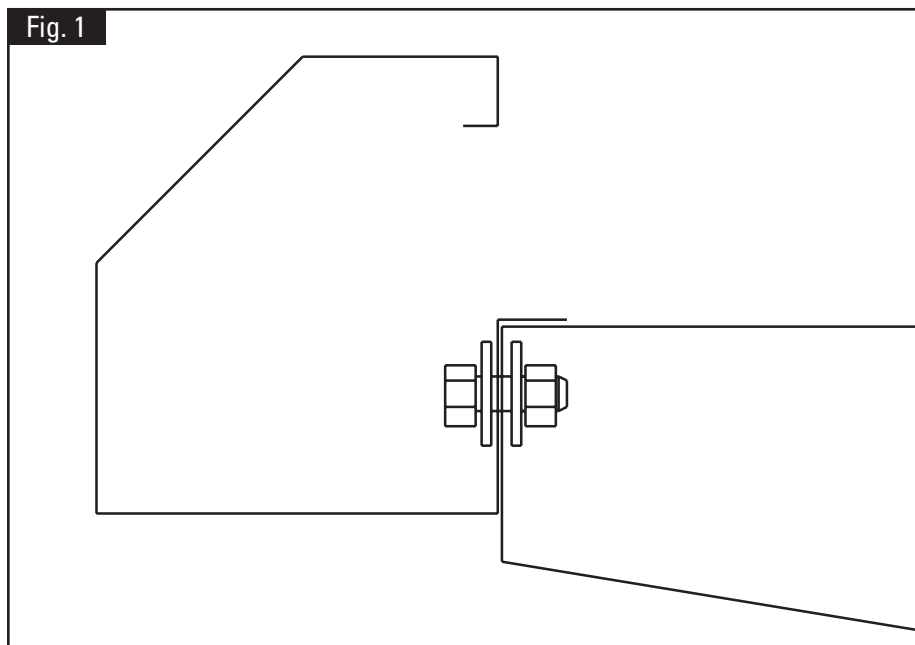



Tarp Spool Kits

Trucks with Long Cab Guards and/or Short Bodies

- a. Mounting position on this type of truck is determined by the placement of the tarp bows. Visualize a line from the opening of the head assembly to the pivot point (Fig. 2). See the Pivot Mounting Instructions for directions on finding the pivot point. **Note:** In situations where it is not possible to keep the bows out of the way of the door or loader, the head assembly should be mounted in a secure location, and the bows bent or angled for clearance (see Bow Installation Instructions).

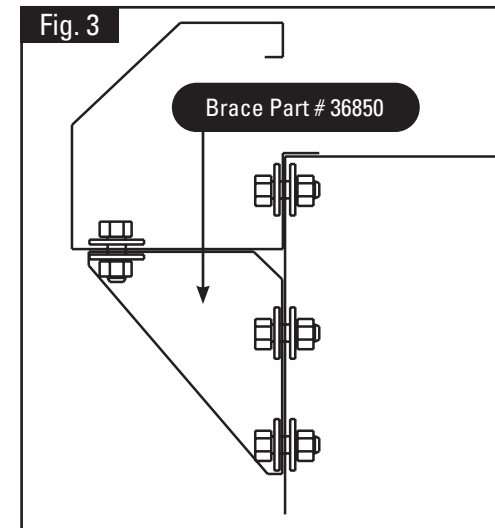
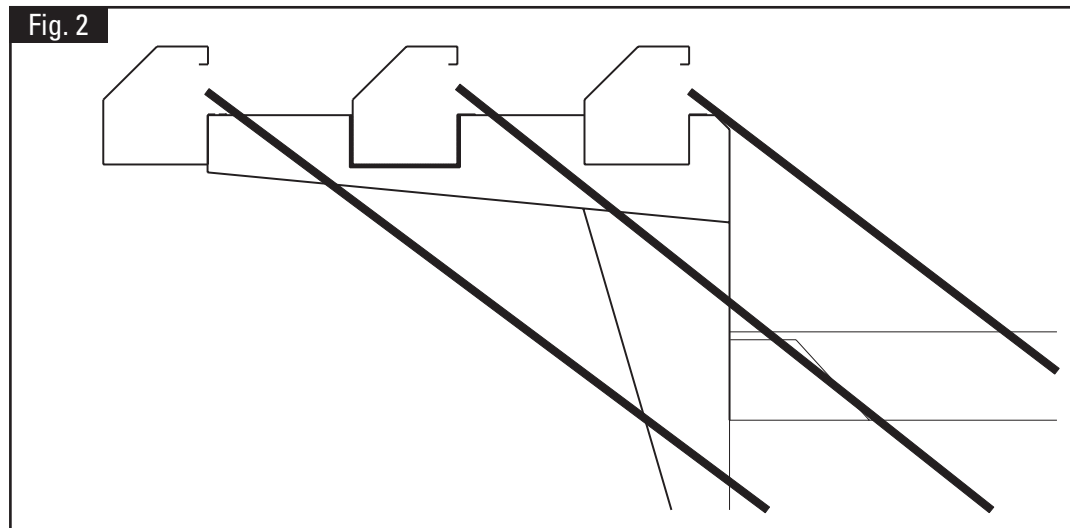

- b. Once you have determined the proper mounting location, either cut a notch in the cab guard to match the shape of the head assembly, or fabricate brackets to hold the head assembly above the edges of the cab guard. **Note:** If you plan to bolt the head assembly in place instead of welding it, avoid cutting a notch so large that it weakens the cab guard. **Note:** If headset is mounted in a location where the front lip is exposed and if installing tarp with grommets along length of the tarp, protection must be added to the lip to prevent it from ripping the tarp. Placing a rubber bumper (pn 36300) at each location where the grommets contact the lip will prevent any damage.
- c. Set the head assembly in position and weld or bolt it in place.

Trailers or Trucks with No Cab Guard

Many trucks or trailers without cab guards have rounded front ends with very little flat area to bolt the head assembly to. In these cases, the head assembly should be braced in some manner. This is important with aluminum trailers which tend to bounce more than steel trailers. You may fabricate a brace or order Part # 36850 (Fig. 3).



Tarp Spool Kits

Trucks with Vertical Stacks

Vertical stacks may be in the way of the side bows if the head assembly were to be mounted at the front of the cab guard. Simply shortening or re-aligning the stack(s) may solve the problem. If this is not possible, it may be necessary to mount the head assembly behind the stacks (see section on long cab guards). If there is not room to mount the head assembly on the cab guard behind the stacks, it may be mounted on top of the board pockets. If it appears that the motor will rest on something in this situation, the entire gear motor should be rotated. This will require that you remove the bolts which hold the gearbox to the head assembly, rotate the gearbox until the mounting bolts line up with another set of available mounting holes, and replace the bolts.

Tarp Spool W/ Wind Deflector and Spool Only

Mounting the Tarp Spool

Choosing the Mounting Location

In general, the gear motor and axle should be mounted on top of the cab guard and as far forward as possible so that the gear motor and side bows will be less likely to be damaged by loaders. The ideal gear motor and axle mounting location is determined by the placement of the tarp bows. It is necessary to visualize a line from the axle to the pivot point (Fig. 4). See the Pivot Mounting Instructions for directions on finding the pivot point.

Exceptions. Trucks with vertical stacks:

Vertical stacks may be in the way of the side bows if the gear motor and axle were to be mounted ahead of the stack(s). Simply shortening or re-aligning the stack(s) may solve the problem. If the stack(s) still get in the way, it may be necessary to mount the gear motor and axle behind the stacks. If there is not room to mount the gear motor and axle in the cab guard behind the stacks, they will need to be mounted on top of the front board pockets. Other exceptions: In some situations it may not be possible to keep the bows out of the way of the loader. In this case, the brackets should be mounted in a secure location, and the bows angled to allow clearance (see Bow Instructions).

Installing the Mounting Brackets (Optional)

Once the mounting location has been determined, you may either install the included mounting brackets using the included 1/2" bolts and nuts, or use the brackets as a template to drill the necessary mounting holes into the cab guard sides or other suitable location.

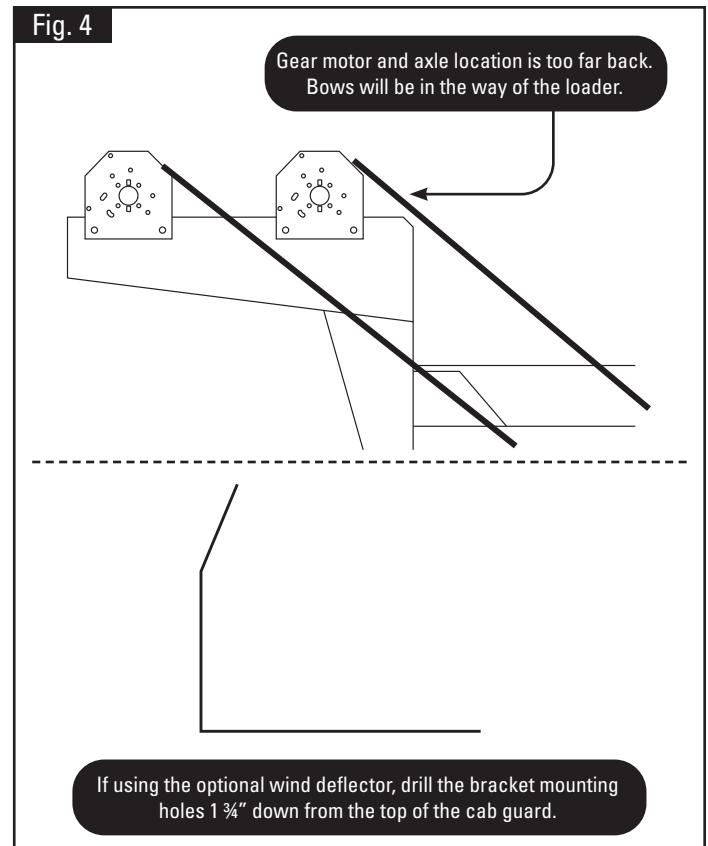



Tarp Spool Kits

Mounting the Gear Motor and Axle

1. Mount the gear motor to the mounting bracket or cab guard.
2. Slide the end of the axle with the cross-drilled hole over the gear motor output shaft. The other end of the axle should stick through the hole where the bearing will be mounted. Slide one of the 5/16 x 2 1/4" bolts packaged with the stub shaft through the hole in the axle and the matching hole in the gear motor output shaft.
3. Mark the other end of the axle 1" from the bearing mounting hole. Cut the axle off at this mark.
4. Drill a cross hole (with clearance for 5/16" bolt) through the axle 3/4" in from the end that was just cut off. Start the hole in one of the round-bottomed slots, not one of the threaded slots.
5. Attach the stub shaft to the axle using the included 5/16 x 2 1/4" bolt. The long end of the shaft (using the hole as reference) should stick out of the axle.
6. Attach the axle to the gear motor output shaft and install the bearing and flange kit. It is a good idea to use an anti-seize product between the axle and both shafts.

Installing the Optional Wind Deflector

Cut the wind deflector to the proper length and attach it to the mounting brackets using the included 3/8 x 1 1/2" self threading bolts.

Tarp Spool W/ Integrated Housing

This Housing is made to be mounted out on the front of the trailer on top of the gussets (part # 36855) provided with it. These gussets are reversible – this allow you to Mount the housing flush with the front of the trailer or to space the housing out 1" from the front of the trailer if need be (Fig. 5).

1. Determine the height at which you want to mount the housing. The gussets can be mounted flush with the top of the trailer or as far as 13" down. Mounting the top of the gusset 12.5" down from the top of the trailer will get the tarp arms completely below the top of the trailer when in the un-tarped position, hence adding no height to your trailer (Fig. 5.)
2. Once the mounting height is determined measure down and mark a horizontal line on the face of the trailer to align the gussets with.
3. The outer gussets should be as wide as possible while still being on the flat face of the trailer. Position the outer 2 gussets and mark their locations.
4. Position the inner 2 gussets evenly between the outer 2 gussets and mark their mounting holes.
5. Drill all mounting holes and bolt gussets in place. Be sure all gussets are on the trailer the same.
6. Set the housing on top of the gussets inserting the pre-installed T-bolts in the holes in the top of the gussets and bolt in place (Fig. 6).

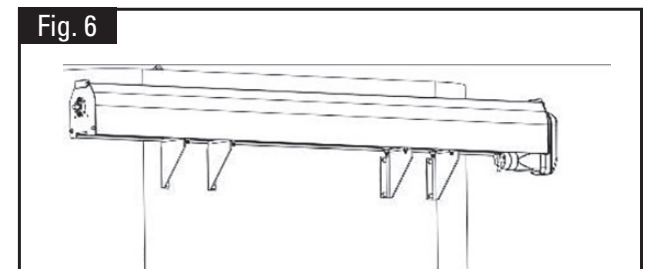
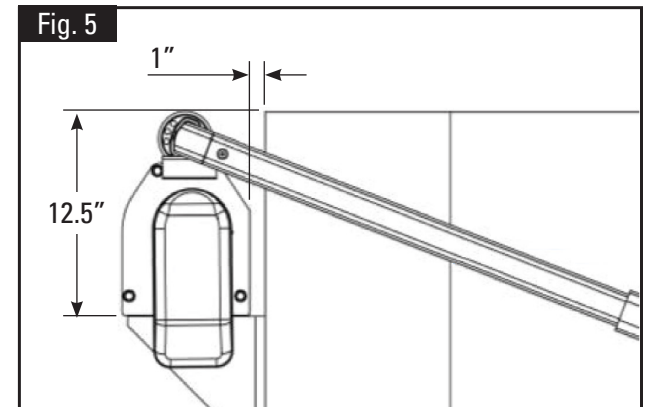

Wiring the Gear Motor

Motor must be wired according to the wiring diagram included with the electric kit. Failure to do so may lead to electrical failure of the motor. **HINT:** Running 3/4" EMT conduit down the front of the body and back along the frame rail provides a safe place to run the wires as well as adding a clean, finished look to the installation. Test the operation of the motor reversing switch. If the direction is incorrect, swapping the two wires on the back of the motor will reverse its rotation.



Pivot Sets

External Pivots

1. Measure from Point A (Fig. 7 on next page) to a point on the side rail of the box that is close to where the pivot should be mounted. Mark this point and note the distance as Measurement X.

The next step will vary depending on your tarp material and application.

2. Choose from the options below.

- B. If you have a mesh tarp:** Using Measurement X from the previous step, measure from Point B (found in Figure 1) and make a 2nd mark on the side rail. **Note:** If Measurement X is large enough, the 1st and 2nd mark may be reversed relative to Figure 1. This will not affect the Pivot Point location.
 - C. If you have a solid/asphalt tarp:** Using Measurement X from the previous step, measure from Point C, which is 4" inside the tailgate, and make a 2nd mark on the side rail. (Refer to figure 1 to determine Point C.) **Note:** If Measurement X is large enough, the 1st and 2nd mark may be reversed relative to Figure 1. This will not affect the Pivot Point location.
 - D. If the tarp is to be extended over the tailgate:** Using Measurement X from the previous step, measure from Point D, which is 5" past the tailgate, and make a 2nd mark on the side rail. (Refer to Figure 1 to determine Point D.) **Note:** If Measurement X is large enough, the 1st and 2nd mark may be reversed relative to Figure 1. This will not affect the Pivot Point location.
3. Divide the distance between the 1st and 2nd mark in half and mark this point as the Pivot Point. Check to see that the distance between the Pivot Point and Point A is the same as the distance between the Pivot Point and Point B, C or D. Erase the 1st and 2nd mark.
 4. To mark the Pivot Point on the other side of the box, measure from the head assembly to the Pivot Point you have already found and use that measurement to mark the other Pivot Point.



INSTALLATION INSTRUCTIONS

Front to Back - Flip Style Tarp Systems

Pivot Sets

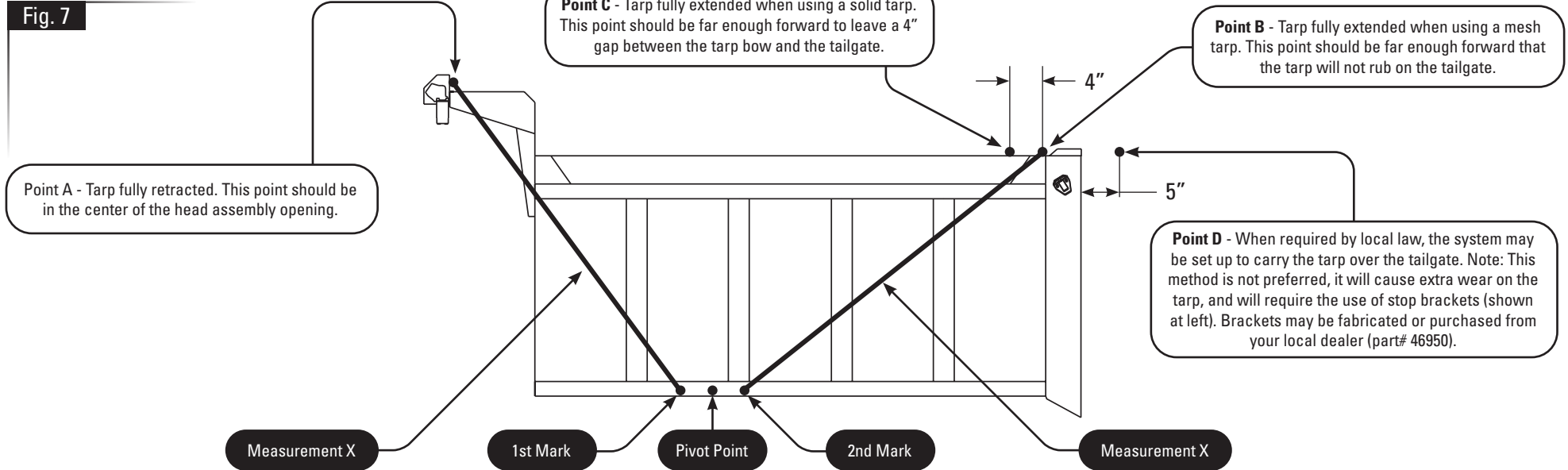

- On each side of the box, drill one $\frac{3}{4}$ " hole 3-3/16" to each side of the Pivot Point. This will give you two holes that are 6 3/8" apart on center.
- Bolt the pivots to the box using the included hardware (the head of the bolt must be on the outside, and the washer and nut on the inside). **Note:** The pivots are directional (see Figure 8 below to determine which is driver and passenger side).
- Thread the included set screws into the pivot tubes, stopping before the set screws extend into the inside of tube.
- To load the springs, rotate the pivots so that the hooks on the springs will clip over the pin inside the spring guard (Fig. 8).

Fig. 8

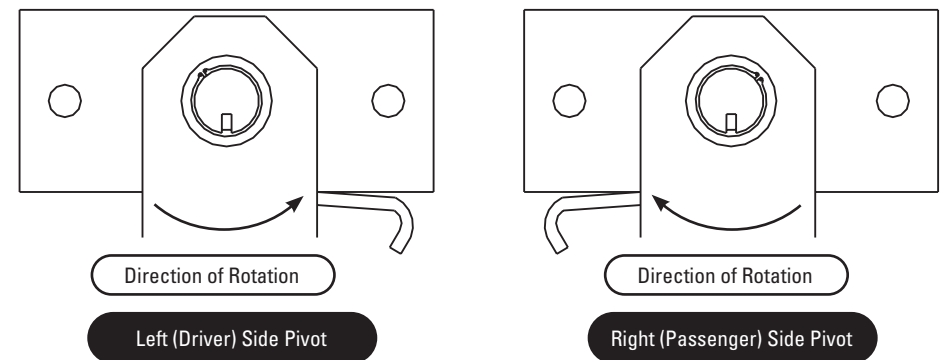



Pivot Sets

Under Body Pivots

1. Remove the pivot assemblies from the box and identify the driver side assembly (Fig. 9).

Fig. 9

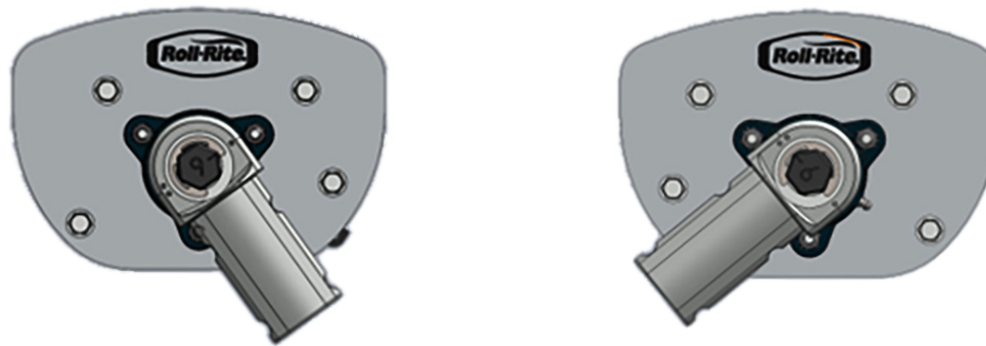

2. Clamp the driver side pivot assembly onto the bottom side rail of the truck or trailer. On trucks with a cab guard, clamp the assembly a few feet ahead of center. On trailers, clamp the assembly near the center of the box.
3. Adjust the location of the assembly until the center of the pivot pin is the same distance from Point A as from Point B (Fig. 10) on the following page.
4. Drill two 3/4" mounting holes in bottom side rail and attach the pivot assembly using the included hardware.
5. **Bolt the pivot assembly to the bottom of the bed using at least one of the bolt holes in the top of the assembly.** If the pivot does not line up with a cross member, you may need to fabricate a bracket. This will prevent excessive twisting of the pivots.



NOTE: Failure to bolt the pivot assembly to the bottom of the box will void the warranty and may create a dangerous situation by subjecting the bracket to forces it was not designed to withstand.



Pivot Sets

Under Body Pivots

Fig. 10

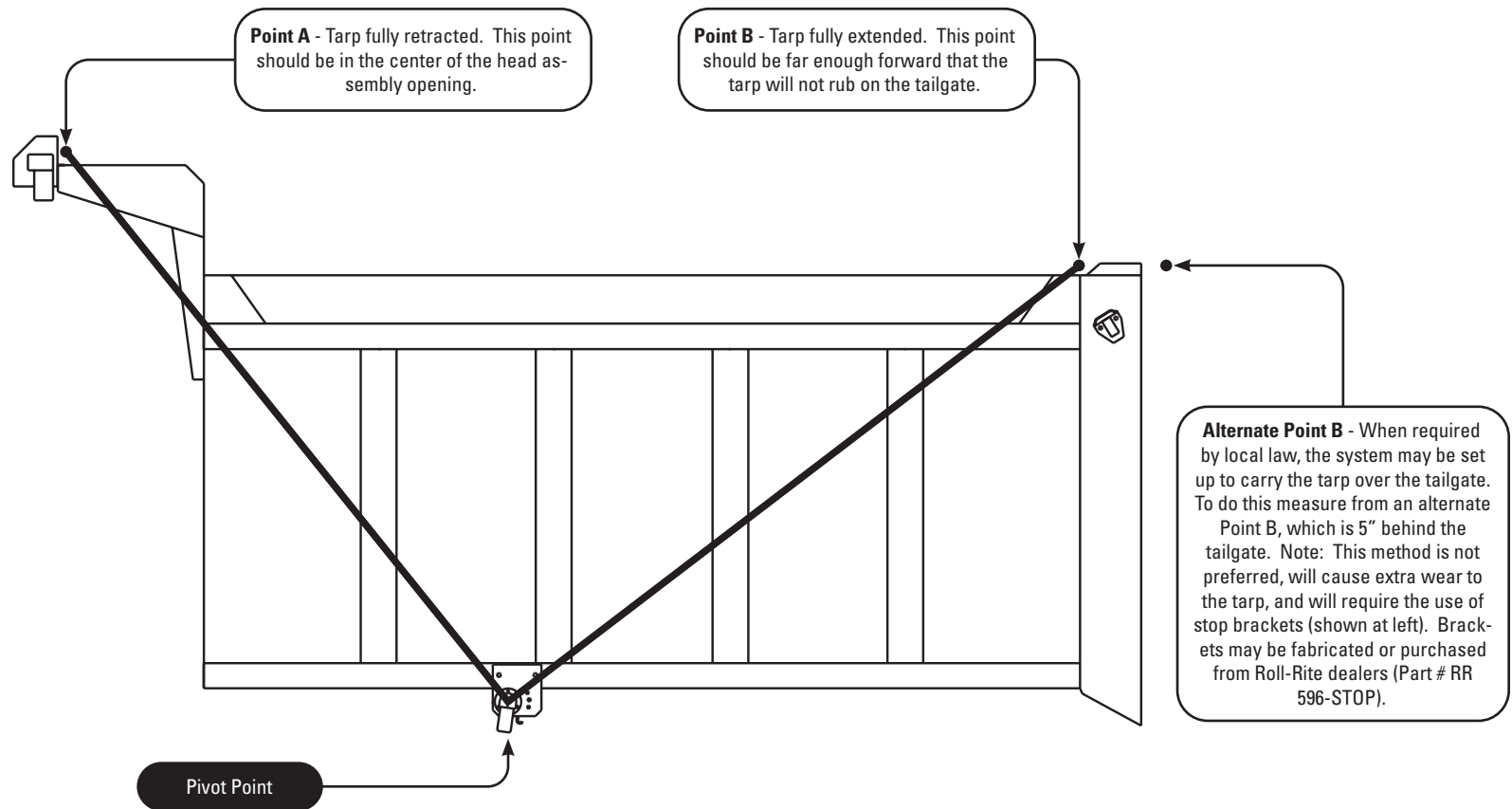

- Repeat the above steps to mount the passenger side pivot assembly.
- Set the position of the clevis pin. The purpose of the adjustment of the clevis pin is to get the correct rotation and power out of the springs. **Warning - too much rotation (over 180°) will cause damage to the springs and reduce the power.** Otherwise, more rotation equals more power. The position of the clevis pin depends on three factors: the height of the tarp spool (depth of body), the length of the body/trailer, and the use of 45° offsets.



Pivot Sets

Knuckle Pivots

1. Remove the pivot assemblies from the box and compare them (Fig. 11).

Fig. 11

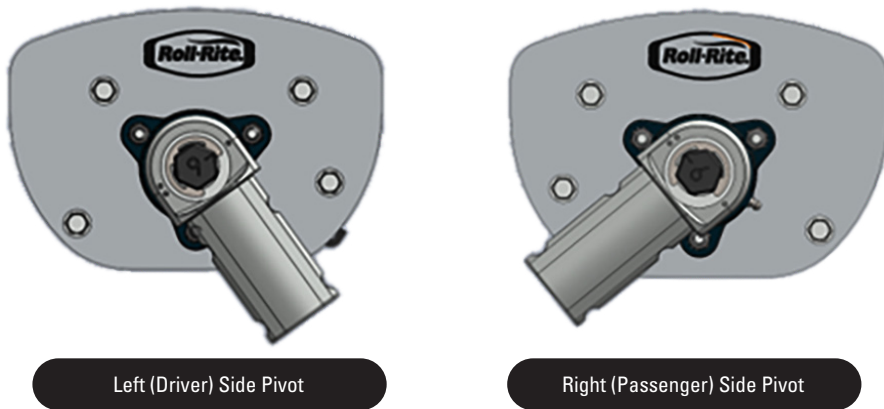
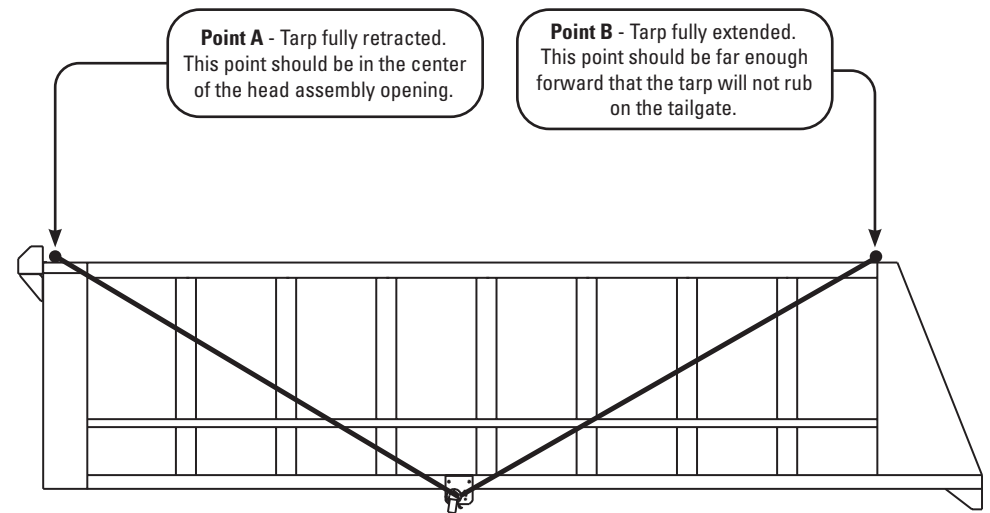

Fig. 12



2. Clamp the driver side pivot assembly onto the bottom side rail of the trailer near the center of the box.
3. Adjust the location of the assembly until the center of the pivot pin is the same distance from **Point A** as from **Point B** (Fig. 12).



Pivot Sets

Knuckle Pivots

4. Drill two 3/4" mounting holes in the side rail and attach the pivot assembly using the included hardware. **Note: Make sure that the outer face of the assembly is parallel with the side of the box.** Shim if necessary to keep the tarp bows from rubbing against the sides of the trailer.
5. **Bolt the pivot assembly to the bottom of the bed using at least one of the bolt holes in the top of the assembly.** If the pivot does not line up with a cross member, you may need to fabricate a bracket. This will prevent excessive twisting of the pivots.



NOTE: Failure to bolt the pivot assembly to the bottom of the trailer will void the warranty and may create a dangerous situation by subjecting the bracket to forces it was not designed to withstand.

6. Mount the passenger side pivot assembly so that it is the same distance from Point A as the driver side pivot.
7. Identify the driver and passenger side pivot tubes by looking for the stickers (Fig. 13).
8. Remove the bolt that holds the pin bracket to the base section of the driver side tube.
9. Remove the snap ring and slide the pin bracket and springs out of the flanges.
10. Slide the upper section into the knuckle until the large holes line up and replace the springs and pin bracket.
11. Reattach the bolt and snap ring. Fully tighten the nylock nut.
12. Install the knuckle bow bumpers (Fig. 13).
 - a. **Note:** Only tighten until the end of the bolt is flush with the outside of the nut. The spring tabs should end up on top of the bolt and the bumper should be installed on the trailer side of the arm.

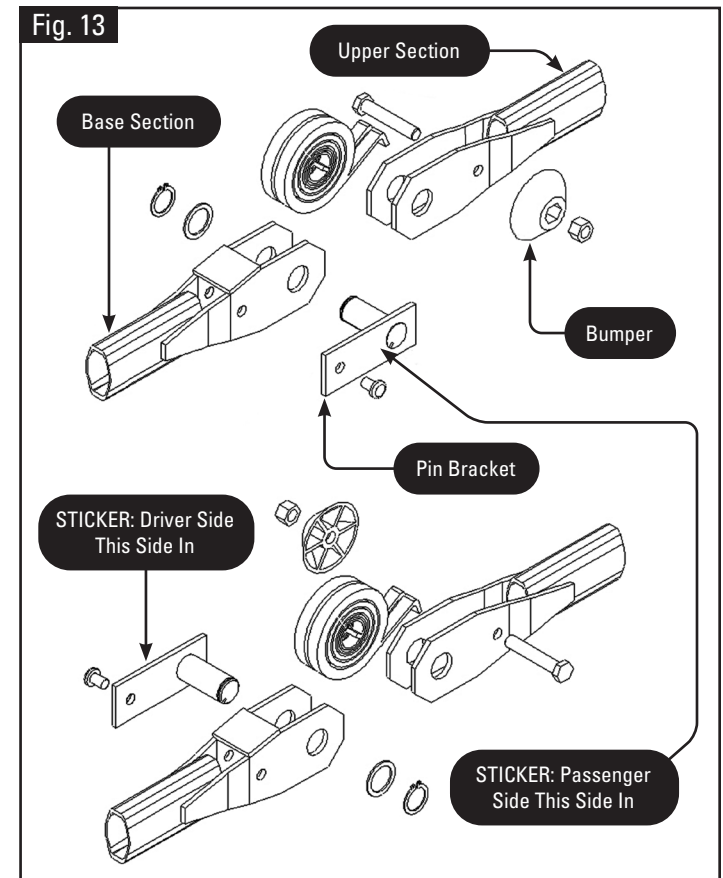



Pivot Sets

Knuckle Pivots

13. Thread the included set screws into the upper pivot tubes,(the arm with the set screws spaced farthest apart) stopping before the set screw extends into the inside of the tube.
14. Repeat steps 8-13 with the passenger side pivot tube.
15. Thread the included set screws into the base pivot tubes, stopping before the set screw extends into the inside of the tube.
16. The pivot tubes are now ready to be mounted to the trailer. To load the main pivot springs, rotate the pivot pins toward the back of the box (using a pipe wrench if necessary) and slide the base end of the pivot tube (the end with the set screws closest together) over the end of the pin with the set screws on the bottom. Tighten the set screws to secure pivot tubes to the pivot pins.
17. Rotate the base section (Fig. 14) high enough to allow the upper section to hang straight down. Rest the end of the upper section on the ground to hold the arms in place.

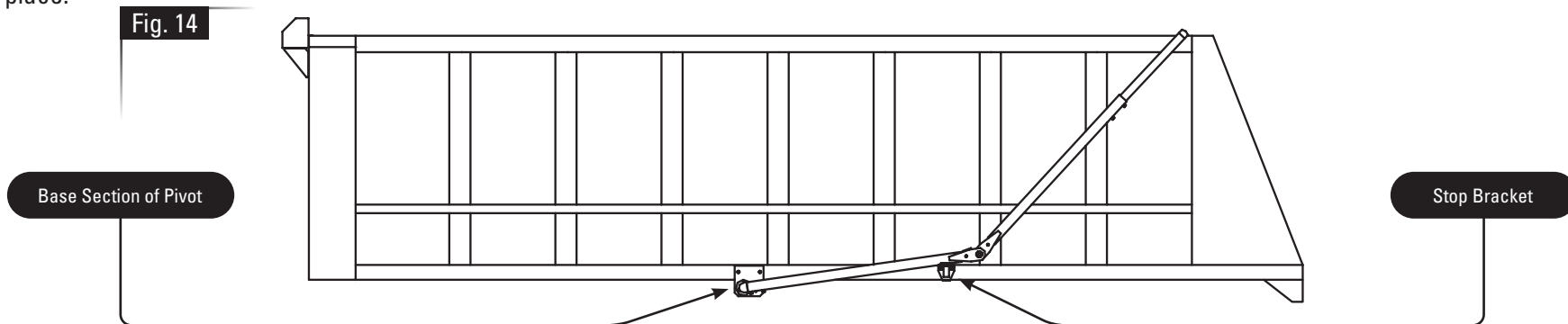

18. Install the stop brackets on the bottom side rail so that the base sections will land as shown in Figure 14. Stop brackets must be mounted so that the lower section of the arm is nearly horizontal to the ground when the arm is extended. If the pivot does not have a sufficient “dog leg” bend, it will not function properly.
19. Rotate the upper section toward the rear of the trailer so that the base sections rest on the stop brackets (Fig. 14).
20. Install the tarp bow and tarp as described by the instructions in the tarp bow box.
21. Perform a final check. Run the tarp in and out several times checking the bows for binding or rubbing against the sides of the box. Adjust the pivot brackets and/or bows as necessary.

Adjusting note: Typical spring setting for this system has the clevis pin in the base box and the knuckle set in the middle setting. To get the knuckle to act more like a straight arm you need to increase the knuckle pressure or decrease the base pressure or a combination of both. To get the knuckle to stay bent for more of the stroke – lower the knuckle pressure or increase the base pressure or a combination of both.

Side Rail Pivots / Transfer Tub / Surface Mount: See Instructions included with your pivot set



Bow Sets

Tarp Bow

1. Be sure that the Tarp Spool and Pivots are installed first.
2. Hold one of the side arms (tube w/ corner) up to the side of the box with the corner against the center of the head assembly opening and with the end of the tube going past the pivot point. If the bow is in the way of the door, or if it will be in the way of the loader, then the bows should be offset. The bows can be offset by calling your dealer and ordering Part # 76900 or # 76910 (30° or 45° Bow Insert). If you have any questions about offsetting the bows, call us at 1-800-297-9905.
3. If the clevis pin that the springs hook on in the pivot is installed remove it. This will allow for ease of arm movement.
4. Bolt a 90° corner into one end of 2 of the arms (Fig. 15).

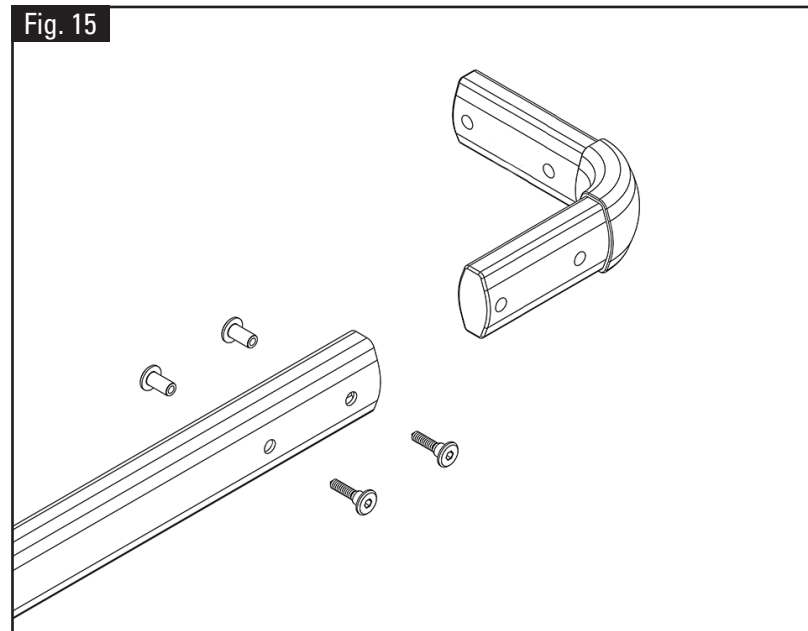

5. Slide one of the side arms into one of the pivot tubes. Adjust the arm length until the corner rests on the desired landing point at the back of the box (Point B from the Pivot Installation Instructions). If the arm is too long, cut both arms to the correct length. Leave about 2 feet of tube sticking into the pivot and make sure that both arms are cut to the same length.



Bow Sets

Tarp Bow

- Slide both side arms into the pivot tubes (make sure that both arms end up the same length) and lightly tighten the two set screws that hold each side arm into the pivots. Final tightening will be done later.
- Slide the 2 pair of tarp flanges, 2 at each end over the 3rd pipe.
- Connect the 2 side arms, using the 3rd pipe, by sliding it over the 90° corners installed in the side arms and bolt in place (Fig.16).
- Swing the assembled tarp bow forward until it rests on the head assembly. The bow should be resting on the rubber bumpers on the tarp spool (Fig. 17A, B, & C) this will vary based on type of tarp spool. If the bow is not landing properly on the rubber pad as desired, loosen the 4 set screws that hold the side arms into the pivots and adjust both bows. Bow side should be adjusted evenly. Lightly re-tighten the set screws.

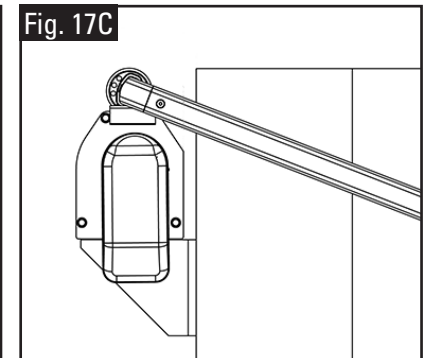
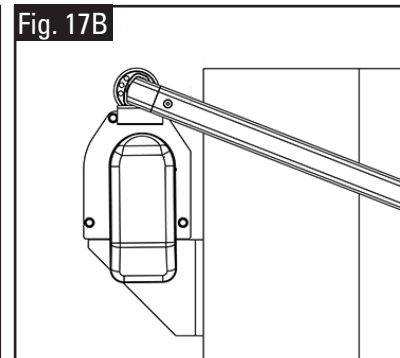
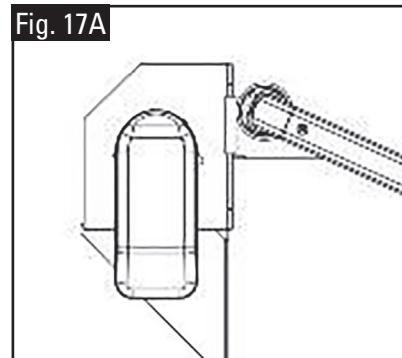
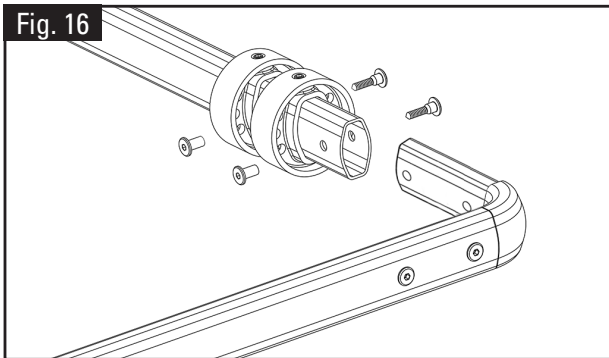

- Swing the bow back to the rear of the truck and check the landing position. If it appears that the bow will interfere with the operation of the tailgate, the pivot point may need to be moved.
- Check for binding or rubbing of the bows against the sides of the box. Check both sides of the box, and adjust the pivot brackets or bows as necessary for clearance.
- Mark both tarp bow side arms where they slide into the pivot tubes. This will allow you to reassemble the bows without re-measuring.
- Remove the tarp tube and side arms so that you may load the pivot springs.
- With the pivot arm rotated down install the clevis pin under the spring tails and secure with cotter pin.
- If your system has a tension bow proceed with steps 1 & 2 under Tension bow installation at this time, this will save you having to disassemble later, then come back here to Step 16.
- Pre-load the pivot springs by rotating the pivots one at a time toward the back of the box and up until you are able to reinstall the tarp bow side arms. Slide the side arms in to the marks made in Step 10 and tighten the bolts that hold them in place. Make sure that the hook ends of the springs have clipped over the pin in the spring guard.
- Set the tarp rod across the back of the box, but do not re-install until you have installed the tarp (see Tarp installation section).



Bow Sets

Tension Bow

1. Remove the bow tubes and their holding bolts (one side at a time) so that you can slide the tension bow mounting brackets over the pivot tubes (flat surface toward the box).
2. Position the tension bow mounting brackets on pivot tubes near the middle of the box and tighten the bolts just enough to keep them from sliding.
3. Measure from the bolt in the mounting bracket to Point A and Point B (Fig. 18). Adjust the mounting bracket until the bolt is the same distance from both points.

Fig. 18

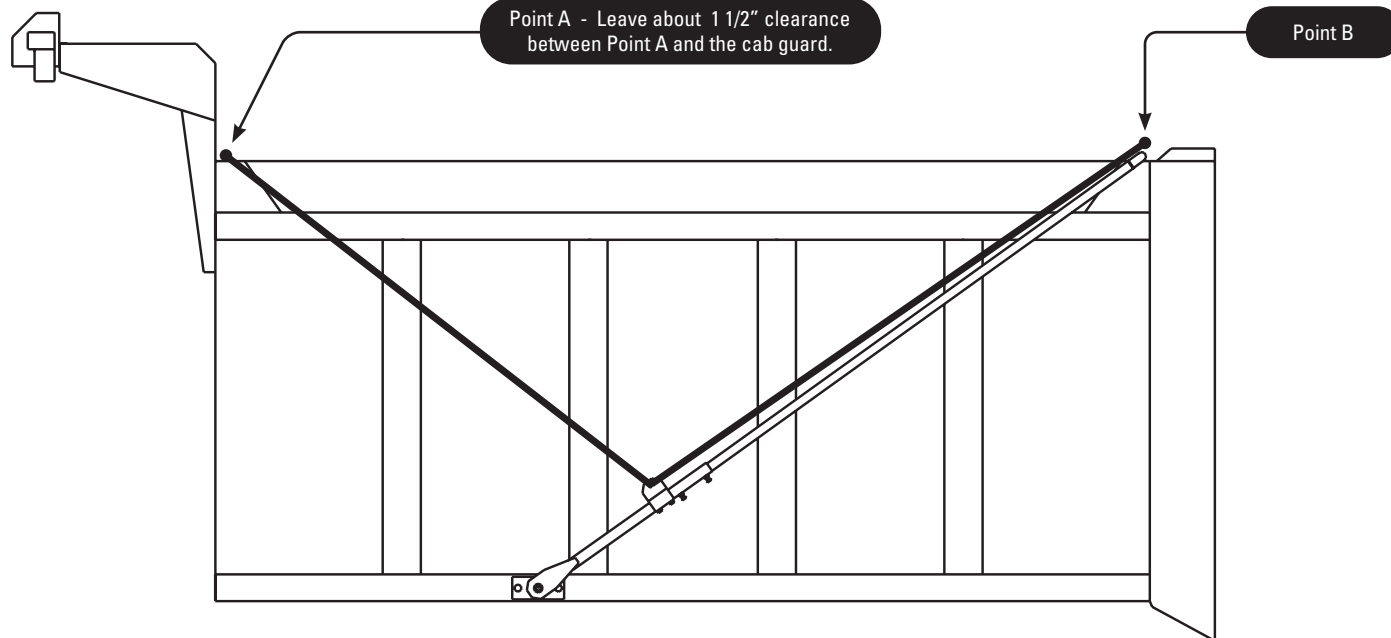

4. Place one of the tension bow arms over the tab mounted to the bracket installed in step 3 and bolt in place (Fig. 19) If the tension bow mount and tab assembly is not assembled (Fig. 20). **Note:** If the tarp bow was angled to clear the cab door or the loading area, then the tension bow arms will have to be angled to match before beginning the next step.



INSTALLATION INSTRUCTIONS

Front to Back - Flip Style Tarp Systems

Bow Sets

Tension Bow

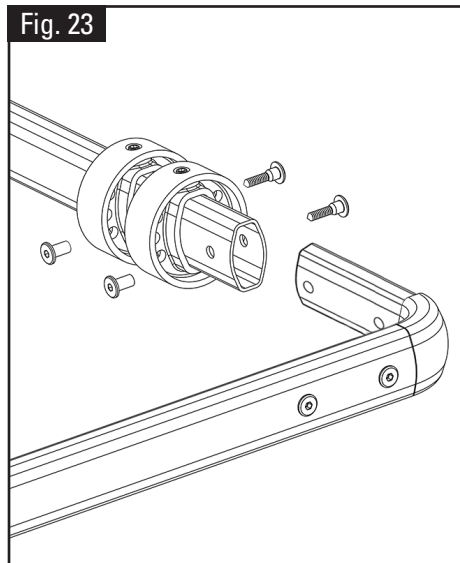
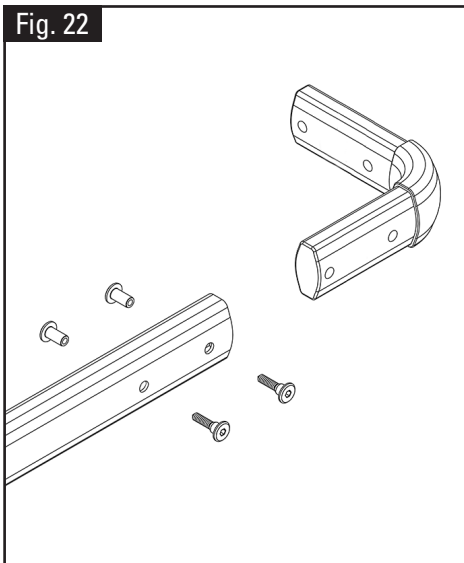
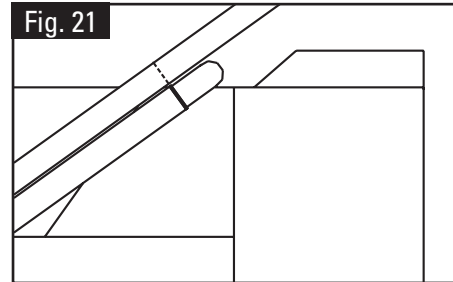
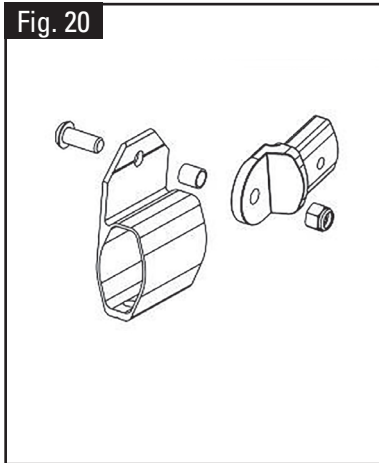
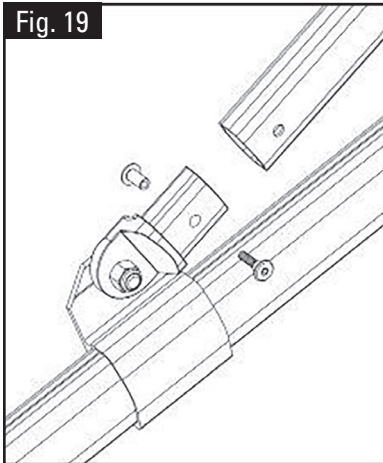

5. Mark the tension bow arm where it rests on the seam between the corner and the bow arm (Fig. 21). Remove the side arm and cut **both** of the side arms to the length marked.
6. Drill the newly cut end of the side arm to match how it was drilled before it was cut off – 1" in from end and centered.
7. Repeat process above with opposite side.
8. Install the 90° corners in the newly cut ends of the tension bow side arms and bolt them in place (Fig. 22) The corners should be pointing in toward the dump body at this point.
9. Slide the pair of tarp flanges onto the rear bar and then connect the side arms by bolting the rear bar to the exposed ends of the 90° corners (Fig. 23).
10. Swing the tension bow forward. If there is not about 1 ½" clearance between the bow and the cab guard, make any necessary adjustments.



Bow Sets

Final Adjustments

1. Swing both bows forward until they rest on the head assembly. The tension bow should rest in the middle of the head assembly opening and the tarp bow should be a little shorter than the tension bow. If not, reposition the mounting brackets and/or adjust the bows until they match (Fig. 24A & B).

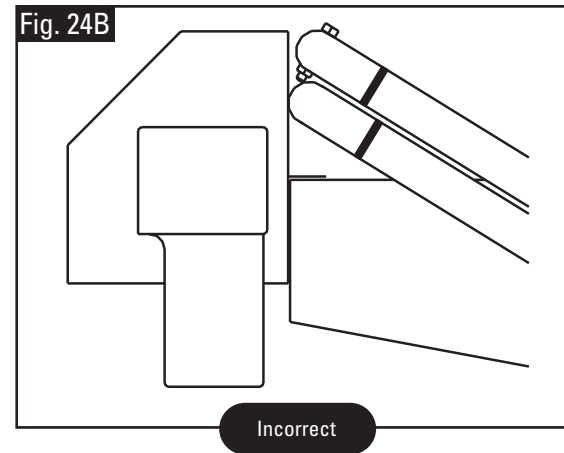
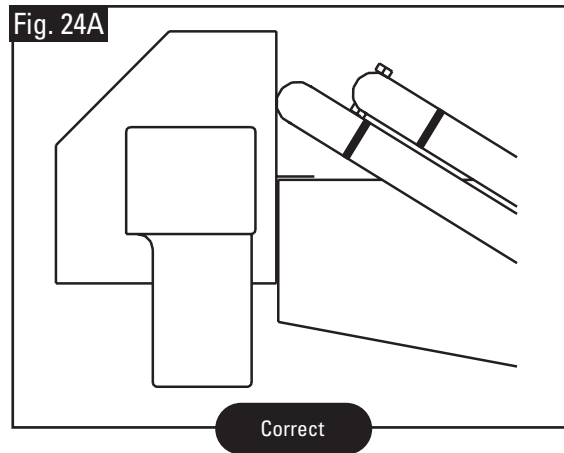

2. Check to see if the tension bow is catching on the lip of the head assembly as the tarp is wound in. In some situations where the head assembly has been mounted at the rear edge of the cab guard, the tension bow may pinch the tarp against the lip of the head assembly. In some cases this may trip the circuit breaker and/or tear the tarp. Adjust bows as necessary.
3. Check all bolts for proper tightness.
4. Run the tarp in and out several times checking the bows for binding or rubbing against the sides of the box. Adjust as necessary.

Installing the Tarp

1. Line the five grommets on the front edge of the tarp up with one of the threaded grooves in the front tarp axle.
2. Attach the tarp to the front axle with 5/16" x 5/8" button head bolts.
3. Slide the rear tarp rod through the pocket in the back of the tarp and center.
4. Slide two of the included tarp flanges onto each end of the tarp rod and re-attach the tarp rod to the side bows.
5. Slide the inner pair of tarp flanges up against the edges of the tarp and tighten the set screws securely. These flanges will keep the tarp from shifting side-to-side.
6. Adjust the outer pair of tarp flanges so that they act as bumpers between the bow and the side rails of the box and/or tarp spool.



Operating Manual

This manual should be kept with the system for the operator to refer to. Improper installation, use, or operator error causing damage to the system is not covered under warranty.

For correct installation refer to the installation instructions provided with component parts.

Note: Improper installation or use of parts other than those supplied with the Roll-Rite System can cause product damage or unnecessary wear that will void warranty.

Winding and Unwinding Tarp

- Winding and unwinding takes only a matter of seconds and should be done at the pit or job site. Winding and unwinding should be done at speeds less than 20 mph. Winding and unwinding at higher speeds can cause damage if the wind catches the tarp or if the tarp bows hit trees, overpasses, bridges, power lines, etc.
- Tarp should always be wound up **over** the top of the axle shaft. Winding tarp under axle may roll gravel, debris, etc. up into the tarp and damage the tarp or cause the tarp to jam in the head assembly.
- In the winter, check for ice in the head assembly before operating the system. If the tarp is frozen to the bottom of the housing, operating the system may damage the tarp or trip the circuit breaker.



Caution for High Wind Areas

If the operator sees the wind lifting the tarp bow, then the bows must be tied down to prevent damage to the system and the tarp.

Tarping an empty truck or trailer may also cause wind problems. Due to the void under the tarp, the tarp will hang low in the center. Wind passing over the low hanging tarp then creates a vacuum that repeatedly picks the tarp up and slams it back down. Wind picking the tarp bow up and slamming it down can and will:

- Bend or break the tarp bows and pivots.
- Cause shock damage to the gear motor.
- Tear the tarp.
- Bend the tarp axle.

Wind damage is not covered under warranty. It is the operator's responsibility to secure the side arms if wind is a problem.



Operating Manual

Pivots and Bows

- A daily visual check of the system is recommended. Check to make sure the side arms are not rubbing the box or binding up. If this occurs, excess load on the motor may cause circuit breaker to trip.
- Check to make sure side arms are held securely in side pivot tubes.
- Replace bent arms or worn or broken springs as they cause uneven wear and stress on the rest of the system.

Gear Motor

- The gear motor is a sealed unit from the factory and is not serviceable by owner or dealer. The gearbox is lubricated from factory with a special lubricant. Addition or use of other lubricants in the gearbox is unnecessary and voids warranty. **Gearbox should never be separated from motor;** this voids the warranty and may cause damage to the worm gear.
- If there is a problem with the gear motor (e.g. no power, power only one way, slow operation, etc.), steps must be taken to determine the exact source of the problem. Perform the following checks before removing the gear motor.
 - » Disconnect both motor wires from the motor terminals.
 - » Using a fully charged 12 volt battery, hook a pair of jumper cables with 6 ga. wire or larger, between the battery and the motor terminals **momentarily**. (Do not use a battery charger.)
- If motor runs when connected to the supplemental power source, then the motor is OK and the problem is in the relay, switch, circuit breaker, or wiring. Swap the test wires on the motor leads and the motor should run in the opposite direction. If the motor also runs in the opposite direction, check for the following:
 - » Poor connections or broken wires.
 - » Small gauge wire not capable of carrying enough amps or excessive wire length. Wire length should never exceed 85' with 6 gage wire. (see Tarp Spool Mounting Instructions).
 - » Tarp spiraling or slipping on axle (see Bow Mounting Instructions).
 - » Circuit breaker tripping.
 - » Defective or damaged relay.
 - » Defective or damaged switch.
- If motor does not run when connected to the supplemental power source, then remove it and return for inspection as specified in the Warranty.



Maintenance Manual

Roll Rite, LLC designs its tarping systems and power kits to be as maintenance free as possible, contributing to the overall value of the product.

Maintenance intervals vary based on environmental conditions.

Roll Rite, LLC recommends that:

- All electrical connections should be cleaned and greased regularly to prevent corrosion (fill all electrical boots, limit switch boots, etc. with dielectric grease). Electrical connections can be found at all motors, switches, contactors, limit switches, control boxes and batteries.
- All bearings with grease fittings and tower legs must be greased regularly.
- Check and tension all set screws. Set screws should be tightened until they touch and then torque them $\frac{3}{4}$ of a revolution beyond that.
- Check motor mounting bolts and torque to 70 in-lbs (5.8 ft-lbs).
- All mounting hardware should be checked to insure all system components are securely fastened.
- Visually inspect all moving parts for abnormal or excessive wear.

Thank you

Roll Rite, LLC designs its tarping systems and power kits to be as maintenance free as possible, contributing to the overall value of the product. Once Again Roll Rite, LLC would like to Thank You for your business and offer you not only the finest product in our industry, but the best customer service as well. We would like to invite you to visit our web site at www.rollrite.com, where you can find a complete set of parts diagrams.

Additionally we would love to hear from you if you have any questions or issues:

- **Phone:** 800-297-9905
- **Fax:** 888 TARP FAX (888-827-7329)
- **E-mail:** info@rollrite.com