

Single Cable Top Slider

Cable Bow System
Installation Instructions

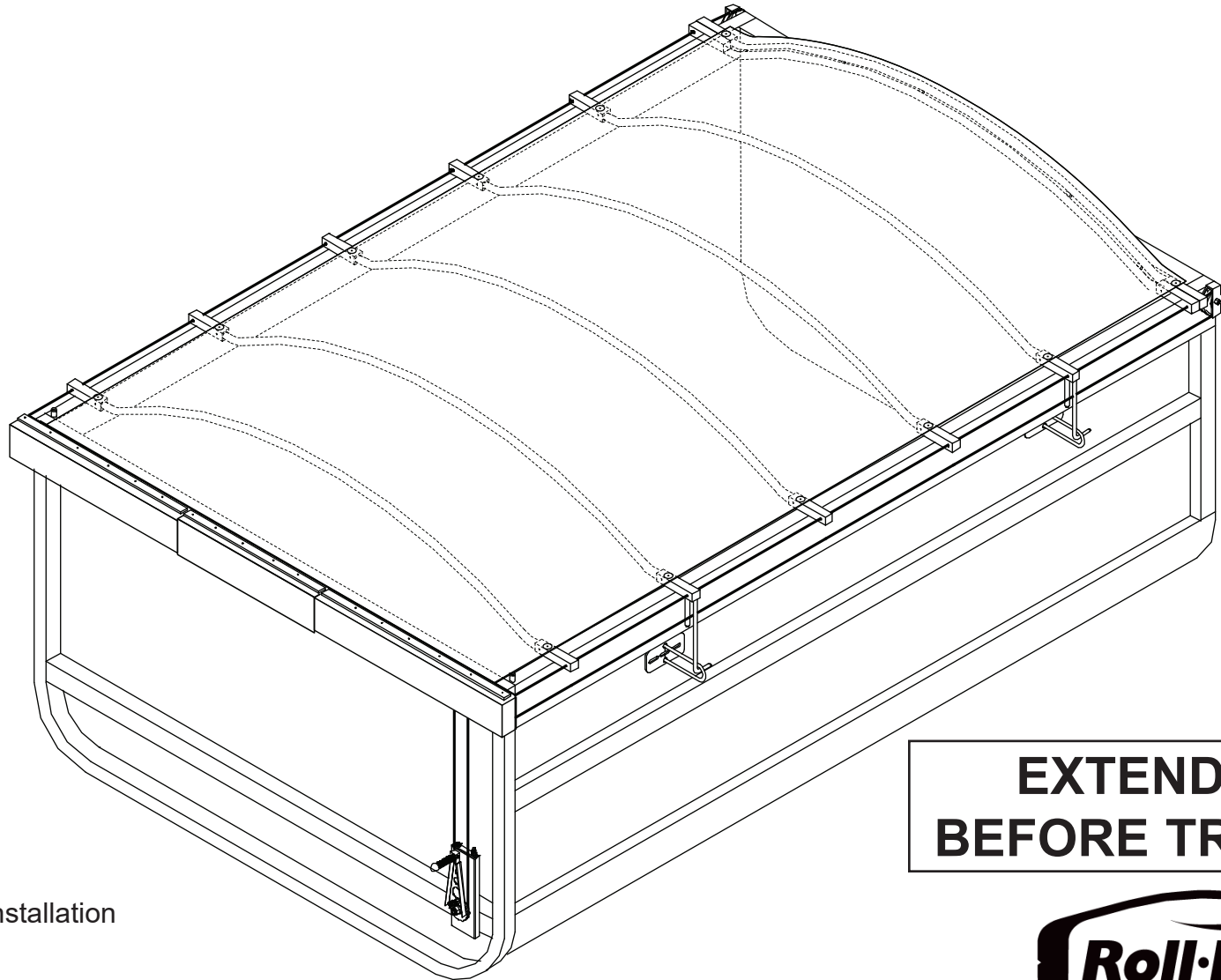

Section 1.
Preparation & Installation

Section 2.
Optional Smart Switch Installation

Section 3.
Parts and Assembly Illustrations

**EXTEND TARP
BEFORE TRAVELING**



A **Clarence Technologies** Company

650 Industrial Drive • Gladwin, MI 48624
For technical support call us at (800) 297-9905

607-0032

Read Instructions Carefully and Completely Before Starting

Important

Proper alignment of bow sliders, pulleys, and cables is critical to the smooth operation of the system. Careful measurements taken at each step are required for the system to be properly aligned. Misaligned cables and pulleys will result in binding and premature wear of the system!

WARNING: Tarp must be fully extended when traveling on the roadway!

NOTE: Tarp must be retracted when dumping and loading.

Step 1. Preparation

Measure trailer at the front, middle & rear of the top rail and record the widest point. Check trailer for square and be sure mounting surfaces are plumb. Irregularities (dents etc.) in the top rail must be repaired to make the top as smooth and straight as possible.

Wood sideboards should be capped with steel channel that is tied into the top rail with steel straps to form a smooth and unobstructed tracking surface on top that is parallel and square.

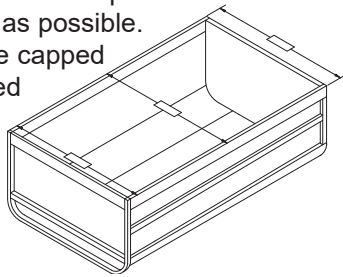

Step 2. Choose Mounting Location

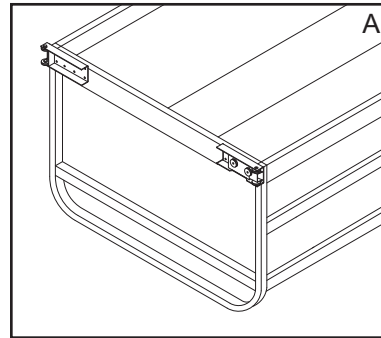

A. Flat top and square front trailer:
Little or no additional fabrication required.

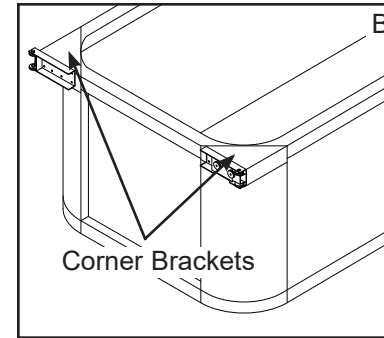

B. Radius Corners:
Front corners must be squared off. Additional fabrication is required. Front Corner Bracket Part # 502-0132 may be required for 18" to 24" radius corners.

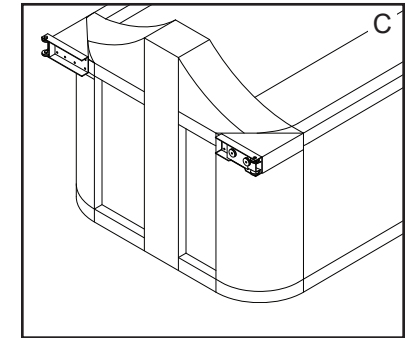

C. Bulkhead or ram box interference:
First Bow must stop short of front pulley boxes and be fixed to the trailer. Front Corner Bracket Part # 502-0132 may be required for 18" to 24" radius corners.

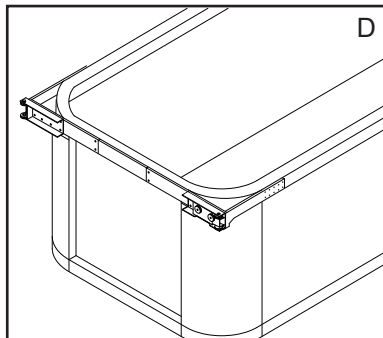

D. Radius Corners:
Front Frame Bracket Kit 502-0103 may be used to square off radiused corners.

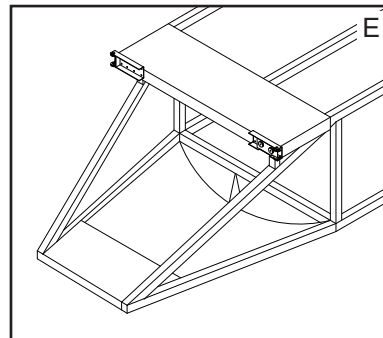

E. Belly Dump:
A front tray should be fabricated to allow tarp to clear opening while loading. Tray should be 24" long in most applications and level with top rails.

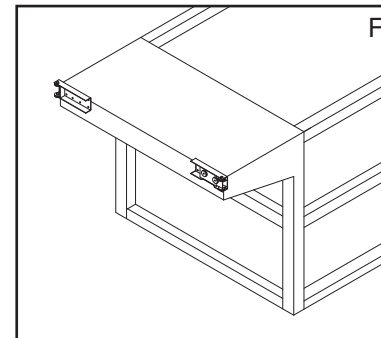

F. Cab Shield Mount:
Fabrication of hand crank mount will be required unless optional side pulley mount is used.

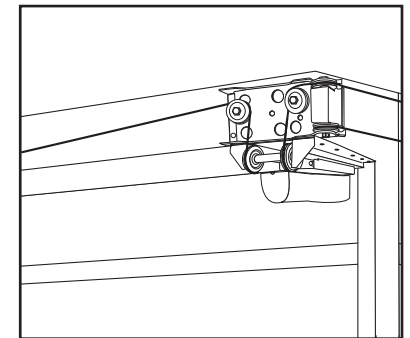

Optional 502-0361 Horizontal motor mount is required for electric drives mounted under trays or cab shields.

Single Cable Top Slider Bows

For complete system orders the bows come pre-cut for your Single Cable Top Slider System.

For parts orders the bows come punched with 5 holes on each side, allowing 19 different widths. They will need to be cut to proper length according to the chart below. When ordering replacement bows, please specify if it is a rear bow.

IMPORTANT: When cutting the rear bow, make sure that you cut the larger increment off on the LEFT SIDE (see rear bow drawing), failure to do this will cause your back flap and tarp to be off-centered.

Example: On a 100" rear bow, you will need to cut 3" off on the right side and 3 1/2" off on the left side. Refer to charts on the right.

For Bows 90 3/4" Wide
Top Slider Cutting Chart
(Cable Center Line 88.5" - 97.5")

Inside Width Cable Center Line	Cut Dimensions	Slider Holes	
		LEFT	RIGHT
97.5"	0"	A	A
97"	1/2" Left Side	A	B
96.5"	1/2" Both Sides	B	B
96"	1/2" Right Side 1" Left Side	A	B
95.5"	1" Both Sides	A	A
95"	1" Right Side 1 1/2" Left Side	A	B
94.5"	1 1/2" Both Sides	B	B
94"	1 1/2" Right Side 2" Left Side	A	B
93.5"	2" Both Sides	A	A
93"	2" Right Side 2 1/2" Left Side	A	B
92.5"	2 1/2" Both Sides	B	B
92"	2 1/2" Right Side 3" Left Side	A	B
91.5"	3" Both Sides	A	A
91"	3" Right Side 3 1/2" Left Side	A	B
90.5"	3 1/2" Both Sides	B	B
90"	3 1/2" Right Side 4" Left Side	A	B
89.5"	4" Both Sides	A	A
89"	4" Right Side 4 1/2" Left Side	A	B
88.5"	4" Both Sides	B	B

For Bows 99 3/4" Wide
Top Slider Cutting Chart
(Cable Center Line 97.5" - 106.5")

Inside Width Cable Center Line	Cut Dimensions	Slider Holes	
		LEFT	RIGHT
106.5"	0"	A	A
106"	1/2" Left Side	A	B
105.5"	1/2" Both Sides	B	B
105"	1/2" Right Side 1" Left Side	A	B
104.5"	1" Both Sides	A	A
104"	1" Right Side 1 1/2" Left Side	A	B
103.5"	1 1/2" Both Sides	B	B
103"	1 1/2" Right Side 2" Left Side	A	B
102.5"	2" Both Sides	A	A
102"	2" Right Side 2 1/2" Left Side	A	B
101.5"	2 1/2" Both Sides	B	B
101"	2 1/2" Right Side 3" Left Side	A	B
100.5"	3" Both Sides	A	A
100"	3" Right Side 3 1/2" Left Side	A	B
99.5"	3 1/2" Both Sides	B	B
99"	3 1/2" Right Side 4" Left Side	A	B
98.5"	4" Both Sides	A	A
98"	4" Right Side 4 1/2" Left Side	A	B
97.5"	4 1/2" Both Sides	B	B

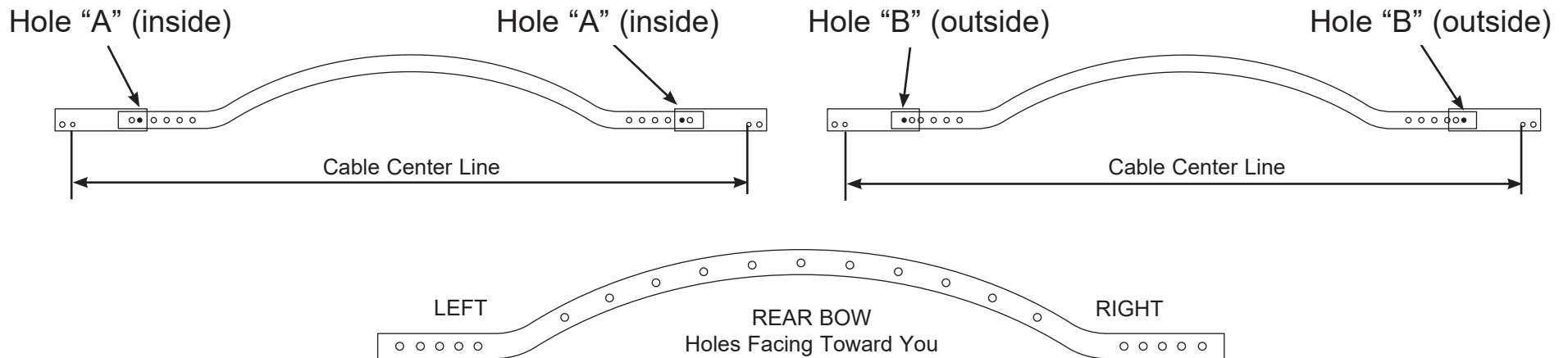

Step 3. Assemble two bows and alignment rods as shown in Fig. 1. *Your bows may need to be cut to the correct width. Refer to section 1 page 2 for Top Slider Cutting Chart.* Insert alignment rods into holes as shown Fig. 1 & Fig. 2.

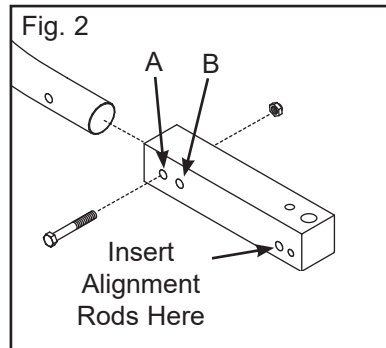
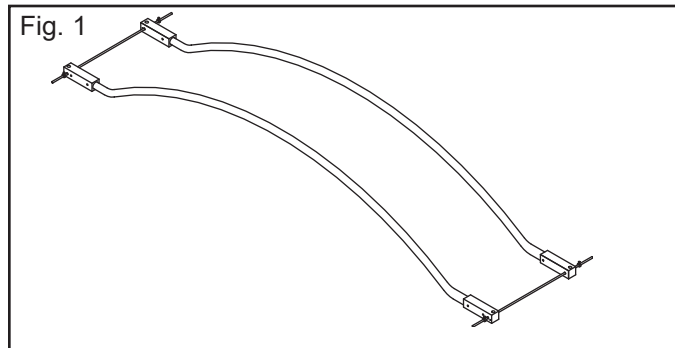

Step 4. Place the bow set with the alignment rods on the top rail at the rear of the trailer. Center the bows on the trailer. Use the alignment rods as a guide to line up the pulleys at the rear of the trailer. Clamp or tack weld pulleys in place (Fig. 6).

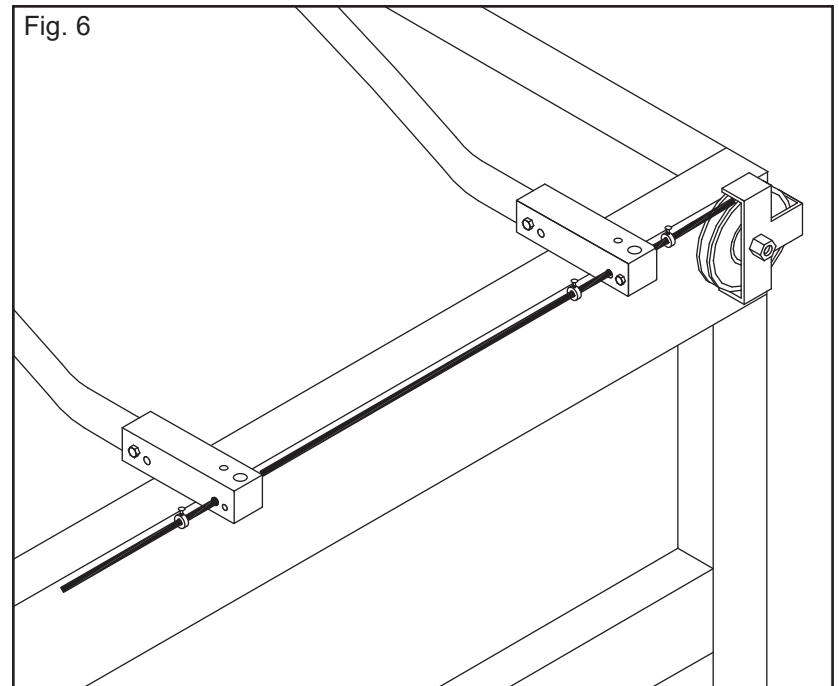

Optional Rear Pulley Mounting Positions (Fig. 3) (Fig. 4) (Fig. 5).

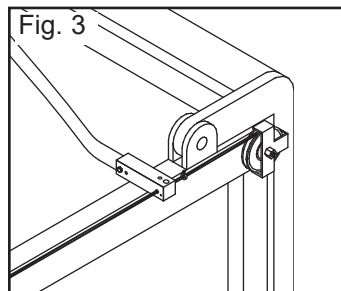

Top Hinge

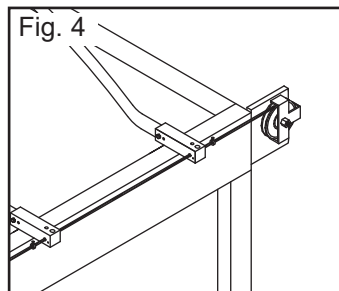

Full Coverage
Beyond Tailgate

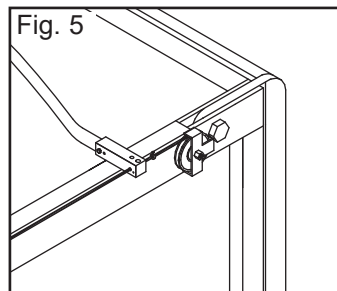

Flush Hinge

Step 5. Move the bow set to the front of the trailer. Use the alignment rods as a guide to line up the front pulley boxes. (Fig. 7)

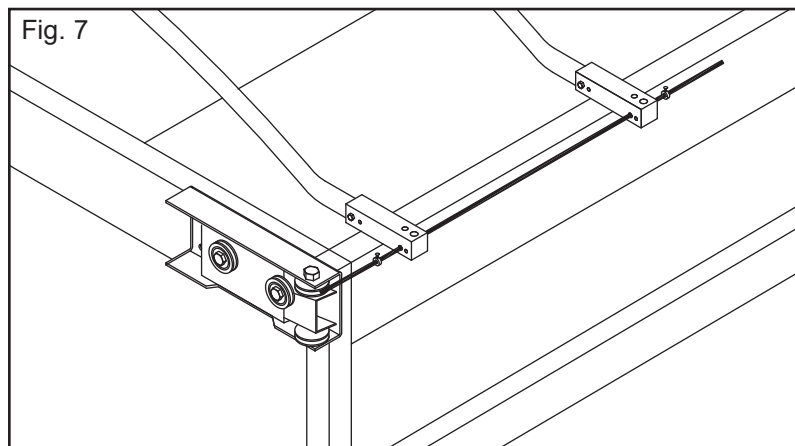

Step 6. Align front pulley boxes with straight edge. Clamp or tack weld in place. (Fig. 8)

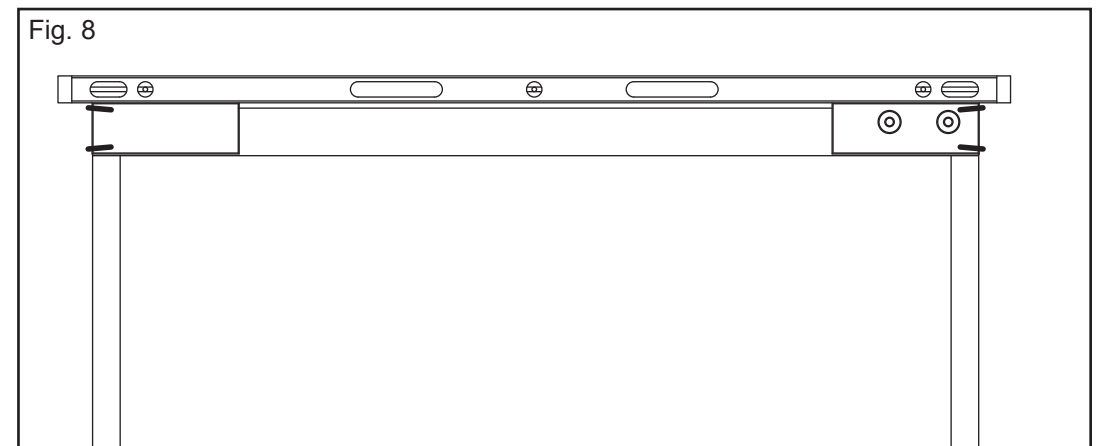

Step 7. Check measurements of front pulley boxes and rear pulley mounts. Width of pulleys must be the same at the front and back (Fig 9). Distance must be the same between pulleys front and rear on both sides (Fig 10). Weld or bolt pulley boxes and rear pulley mounts in place.



Note:
Dimension "A" and "B" (cable center line) must be equal. Cables must be parallel or binding will occur causing hard manual cranking, or motor strain.

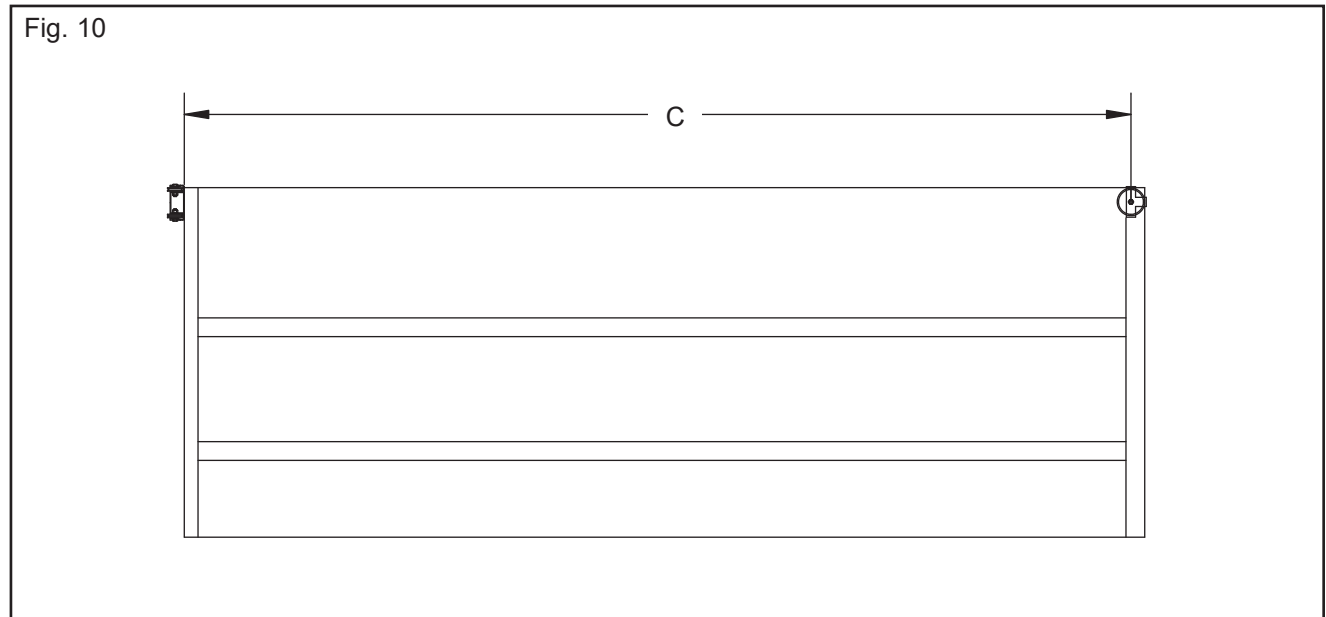

Note:
Dimension "C" Must be equal on both sides.

Step 8. Choose mounting position and assemble drive on base mount

A. Remove cotter pin and washer from base mount and remove the guide shaft. Remove the single nyloc nut from threaded adjusting shaft and remove it from base mount (Fig. 11 & 12).

B. Insert guide shaft through top of base mount and through guide hole in back of drive assembly. Push the shaft all the way through the base mount. Reinstall the washer and cotter pin (Fig. 11 & 12).

C. Thread adjusting shaft through top of base mount and threaded hole in back of drive assembly. Thread shaft through so the nyloc nut can be started on the shaft (Fig. 11 & 12).

Note: When using the optional Side Pulley Box (part # 502-0108) be sure to use the Slider Bracket (part # 502-0451) on the passenger side (Fig. 12). The Slider Bracket acts as a stop on the passenger side and the Side Pulley Box acts as a stop for the driver side. This distance from the front of the body should be the same on both sides (Fig. 12).

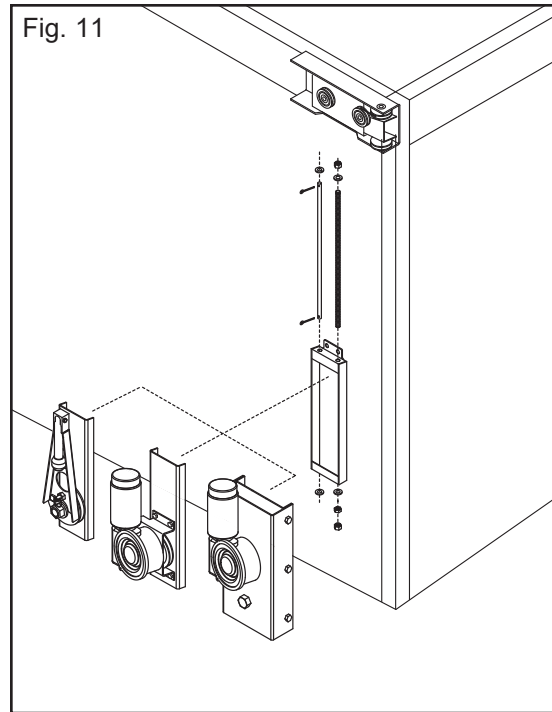

Front Mount

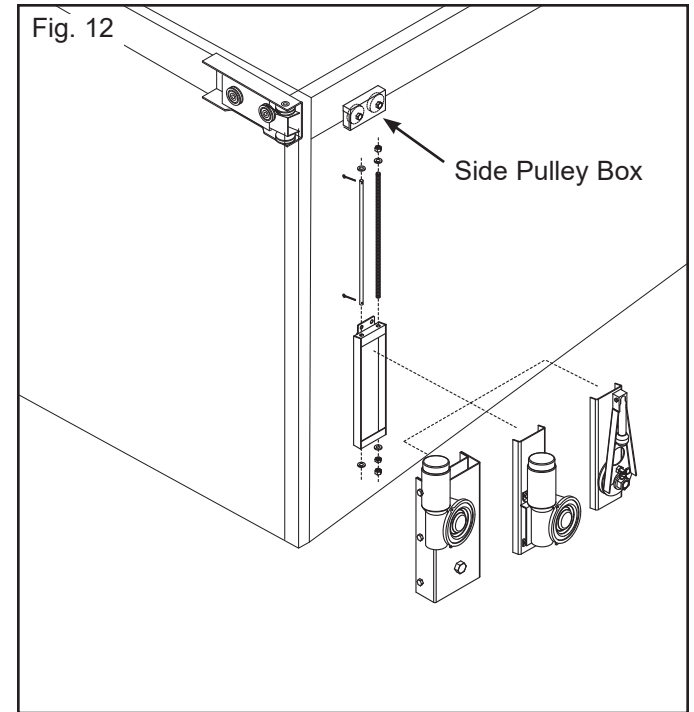

Side Mount

Utilizes optional Side Pulley Box (part # 502-0108) and Slider Bracket on passenger side (part # 502-0451)

Horizontal Motor Mount (part # 502-0361)

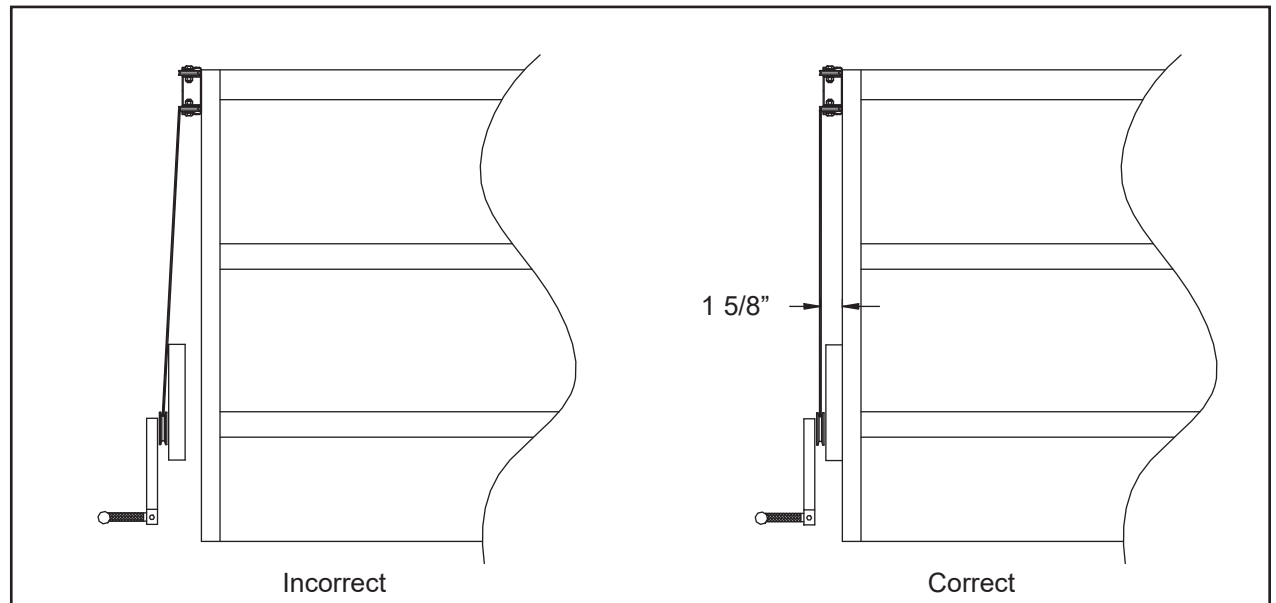
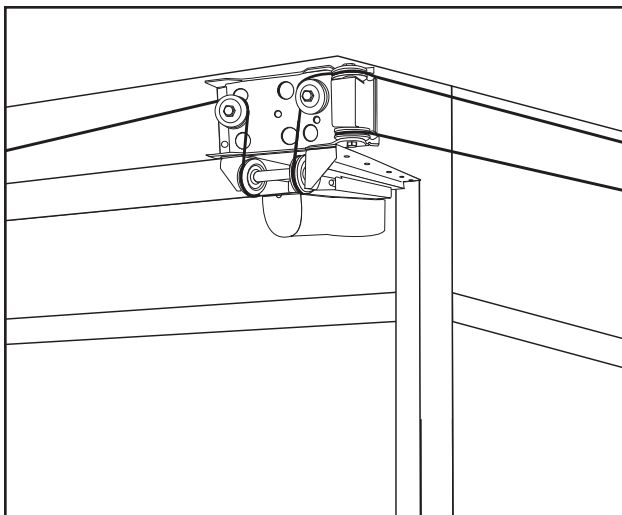

Incorrect

Correct

Step 9. Lay the tarp out on the ground with the pockets facing up. Install bows in tarp pockets and assemble sliders on bow ends. The dual bow set is installed at the rear of the tarp. (Fig. 15 & 16).

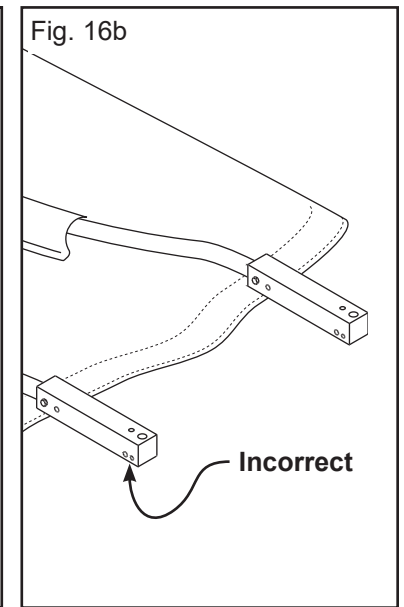
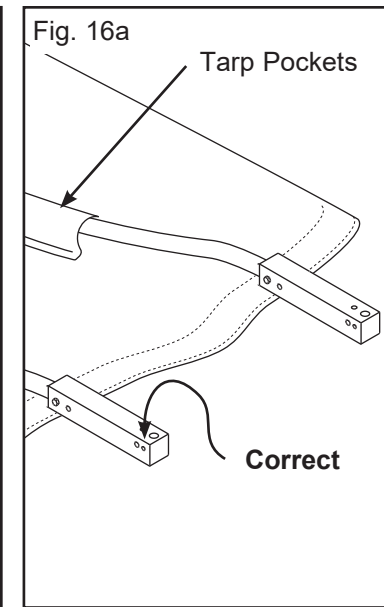
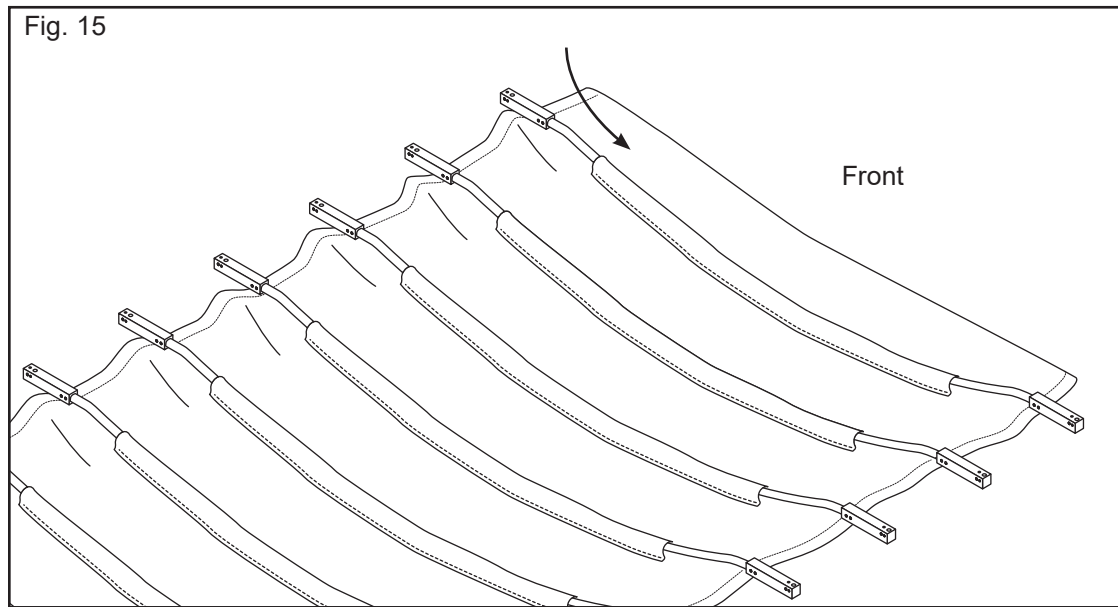

Step 10. Systems with Air Gates (continued on next page).

Insert Air Gate Bow Extensions into rear bow and measure inside width. The inside width of the airgate bows must equal the cable centerline plus 3/4". Cut equal amounts from each end of the bow as needed. After cutting, drill 9/32" hole through bow and bow extension. Install bow in tarp pocket and assemble Air Gate Bow Extension using hardware that comes with bow. (Fig. 17)

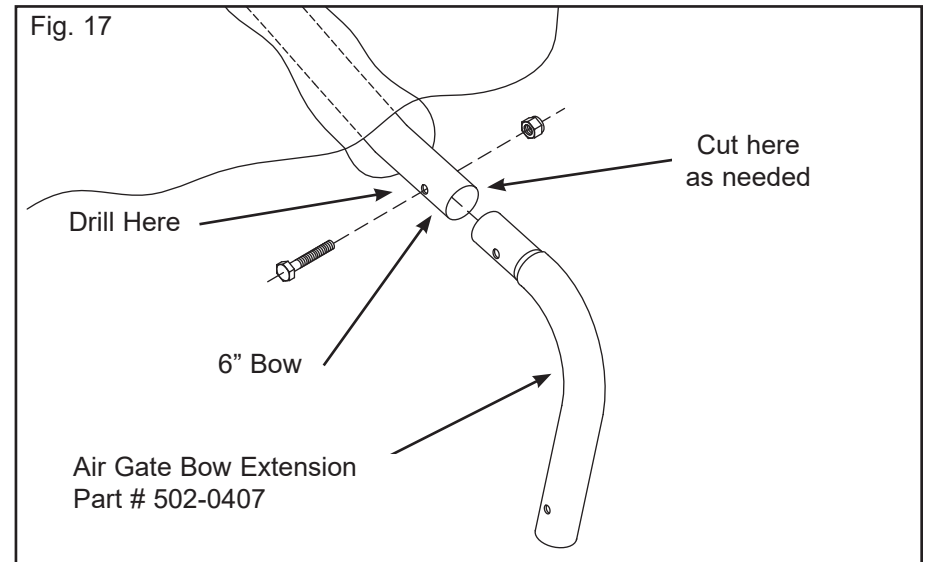
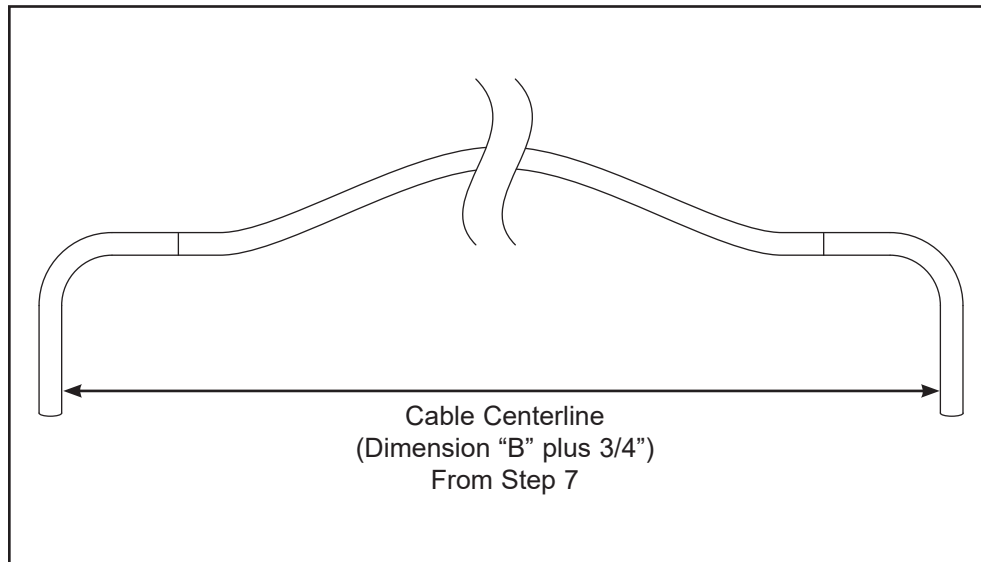

Step 11. Gather all the bows and sliders together on the ground and insert alignment rod through the sliders. Turn the tarp over and place on the trailer (Fig. 18).

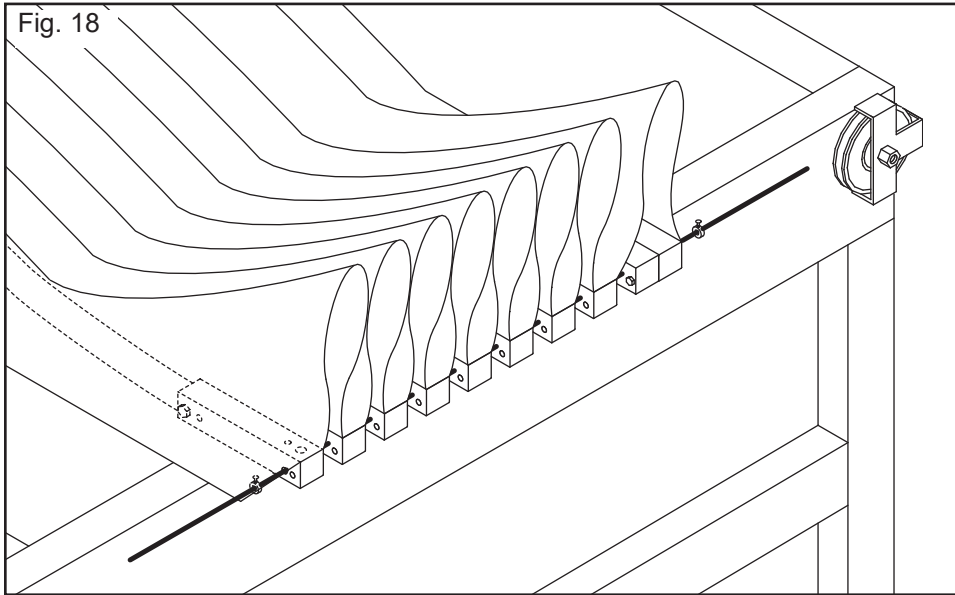

Step 12. Remove the alignment rods and spread the tarp out on the trailer. (Fig. 19).

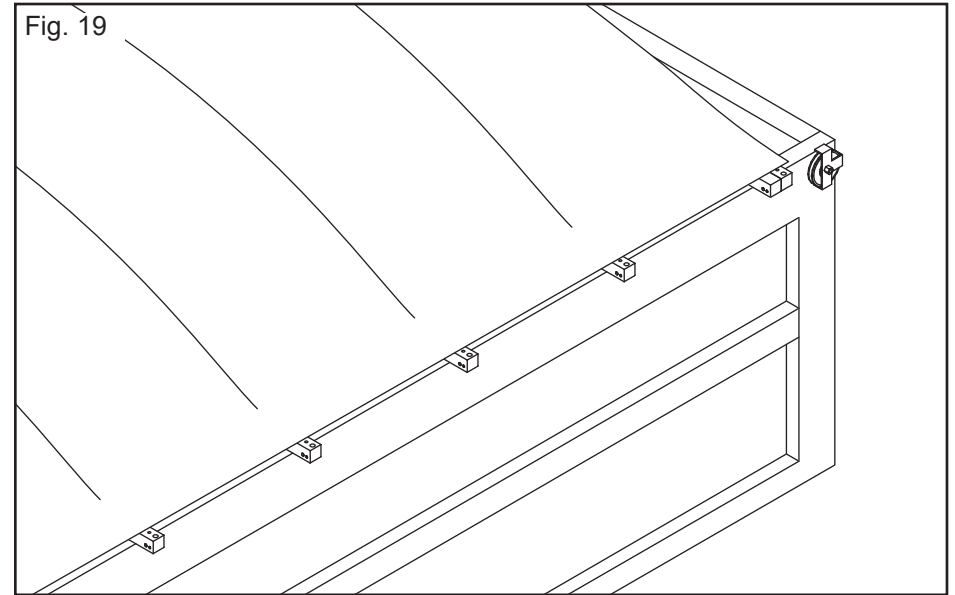

Step 13. Installing the Cable:

To install the cable, stretch the entire cable out on the ground to remove any loops or twists. Thread each end of the cable through the sliders at the same time as shown below. (Fig. 20 - 23).

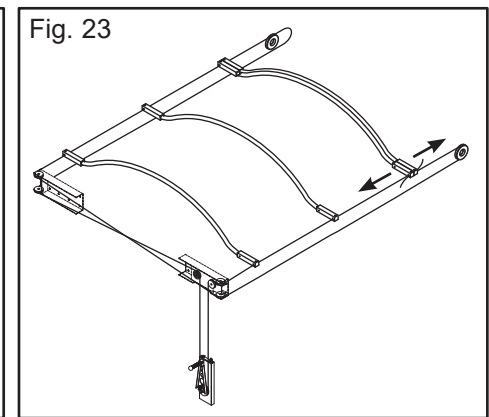
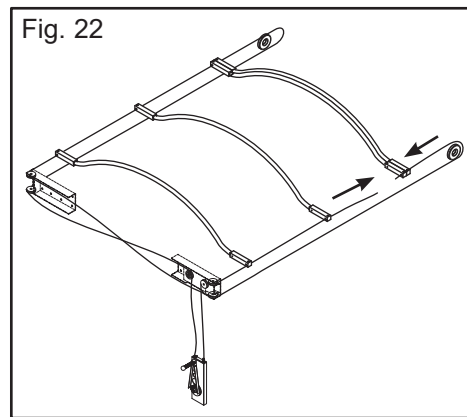
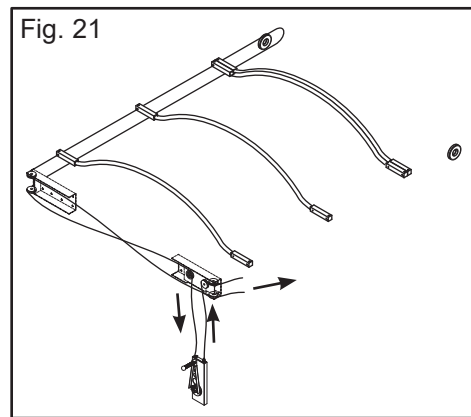
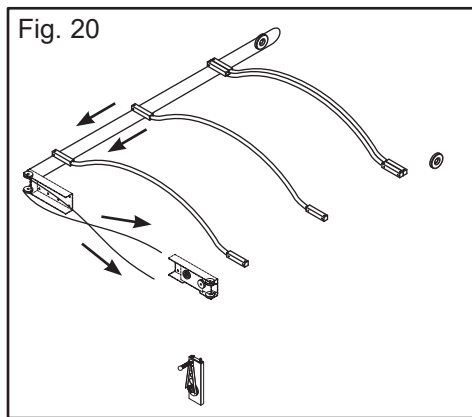

Step 14.

When routing the cable on a Gear Reduction Motor Drive (part # 502-0602) the lower drive pulley must be temporarily removed in order to route the cable (Fig. 24).

- A. Remove 1/2" bolt from lower drive pulley and slide pulley out of the bottom of the cover.
- B. Feed cable down through the drive cover along the right side of the small pulley.
- C. Lay the large drive pulley in the cable loop as shown.
- D. Make sure both bushings are in the bearing of the pulley.
- E. Slide pulley up into the drive cover while pulling cable from the top.
- F. Reinstall 1/2" bolt and lock washer through the cover and pulley and tighten.

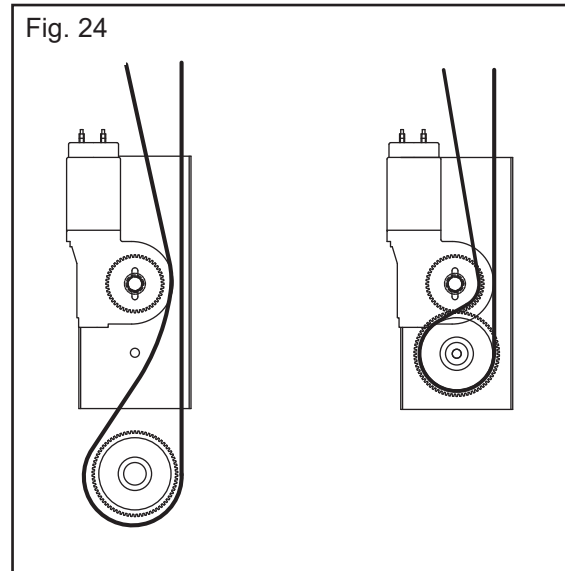

Cable Routing for Other Drives

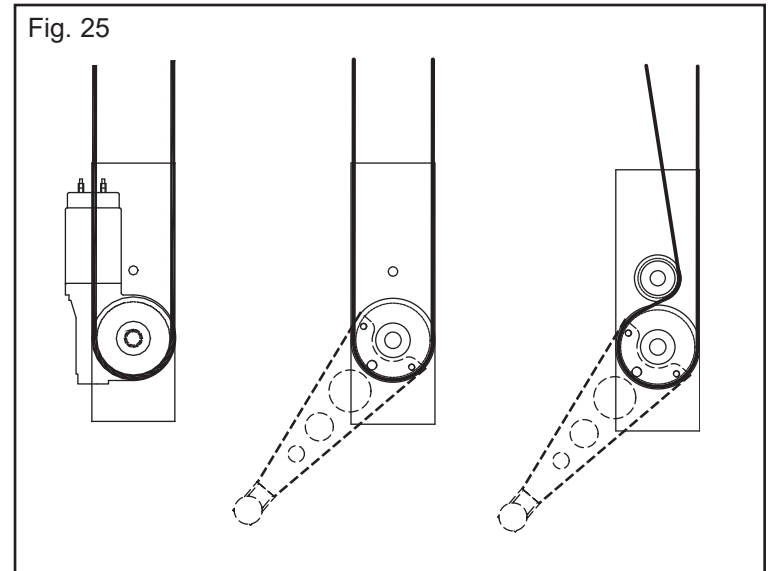

Systems with Air Gates Skip to Step 17.

Step 15. Assemble cable clamps at rear. Pull all slack out of the cable and tighten clamps securely (Fig. 26).

Note: Extending the tarp and bows will support the cable and make it easier to remove the slack.

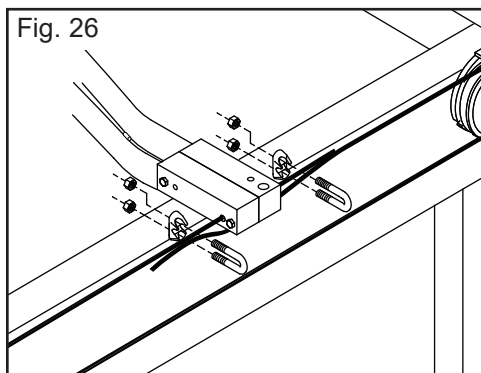

Step 16. On the left side (Driver Side), measure from the back of last slider to the front of the rear pulley (Fig. 27). Adjust the slider on the right side (Passenger Side) to be the same distance from the pulley. Use 3 1/2" long piece of cable along side of the main cable and clamp with cable clamps (Fig. 28), failure to do this will result in excess movement and wear in your rear bow.

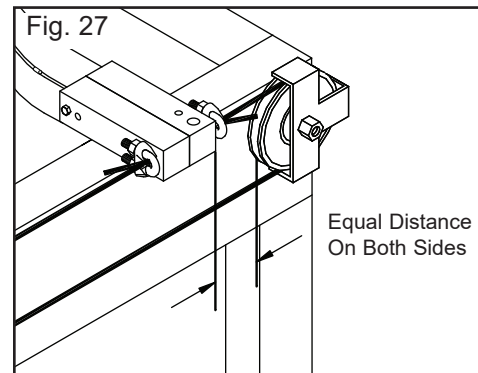

Driver Side Rear

Step 17. Adjust cable tension until the cable just begins to slip on the drive pulley when the system is fully extended, then add one additional full turn (Fig. 29). Recheck measurement from the back of the last slider to the front of the rear pulley on each side. Adjust the slider on passenger side if necessary.

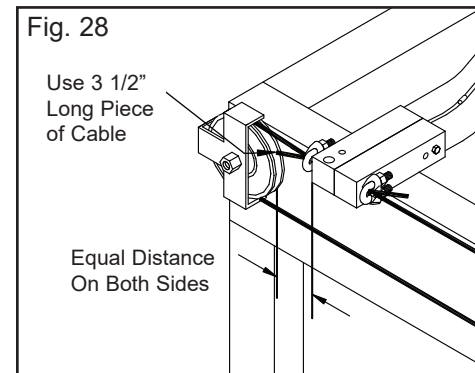

Passenger Side Rear

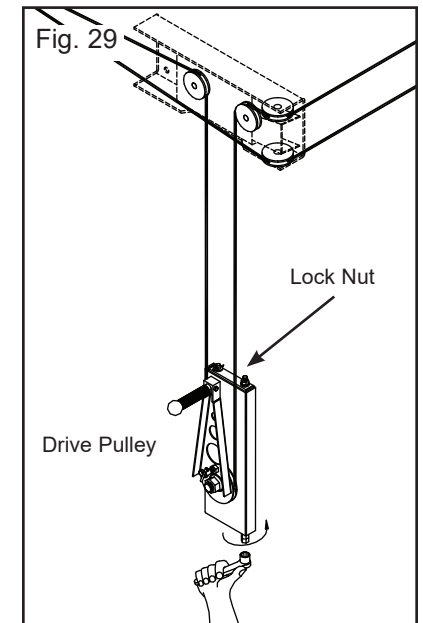

Note: Adjust cable tension by turning adjustment nut on drive clockwise as shown. Tighten the lock nut after adjustment.

Step 18. Systems with Air Gates.

Clamps must face outward at assembly. Pull the slack out of cable. Tighten cable clamps on driver's side. Measure the height needed for the bows to just clear the top of Air Gate. Trim the Air Gate Bow Extensions as needed. Using the Air Gate Sliders as a guide, drill 9/32" hole through Air Gate Bow Extensions and bolt Bows to Sliders. Make sure Driver Side and Passenger Sides are equal height. (Fig. 30).

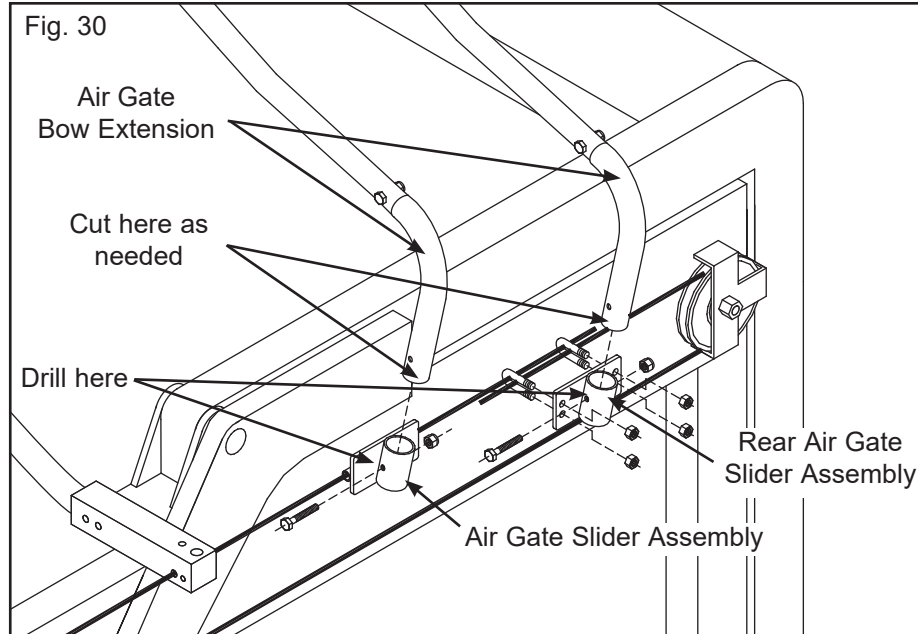

Step 19. System with Air Gates. On left side (Driver Side) measure from back of Rear Air Gate Slider Assembly to the front of the rear pulley (Fig. 31). Adjust the slider on the right side (Passenger Side) to be the same distance from pulley and tighten clamps.

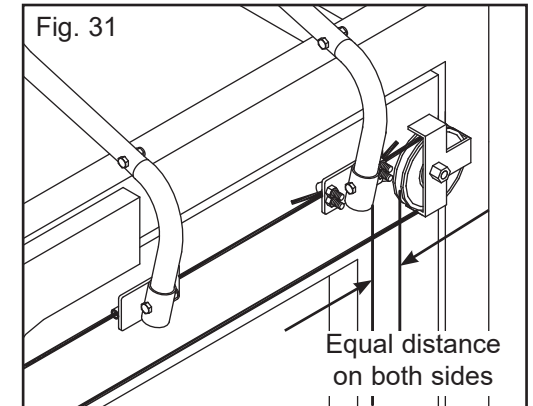

Step 20. Assemble the front cover by sliding the two end pieces into the center section. Install by snapping the cover in place over the pulley boxes (Fig. 32). Adjust the width by telescoping the sections in or out.

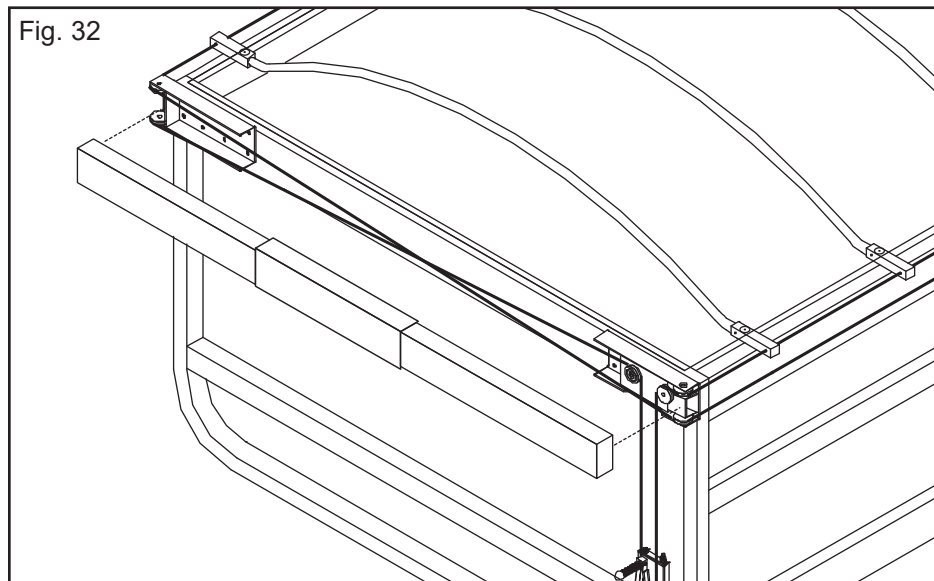

Step 21. Extend the tarp to within two inches of rear of trailer. Pull front of tarp forward to the pulley box cover. Double fabric over hem tube. Pull fabric tight and fasten to front cover using the aluminum mounting strips and self tapping screws (part # 506-9929) (Fig. 33). Be sure the self tapping screws go all the way through and into the pulley box.

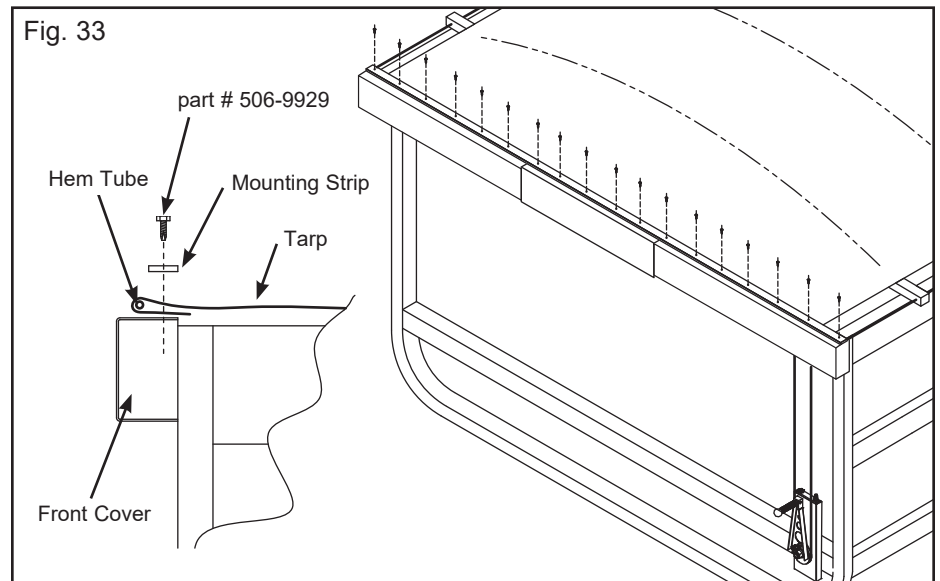

Step 22. Rear Back Flaps and Rear Bow

The back flap is bolted to the last bow. The rear bow comes punched with 11 holes on one side (for the back flap). If you have a 93" rear bow it will only have 9 along the back.

- A. Fasten the tarp to the slider or bow. Use the hex head screw (part # 506-9908) if your tarp overlaps the slider (Fig. 35). If the tarp does not overlap the slider (Fig. 36) or if it overlaps a small amount (Fig. 37), then use the self tapping screw (part # 506-9907) to go through the tarp grommet, slider and bow. Repeat these steps to attach tarp to each bow.
- B. Attach the back flap. The back flap is two separate pieces. The pieces will be overlapped in the center. Attach the back flap and to the rear bow starting from the center. Insert the self drilling screws (part # 506-2505) in the order shown in Fig. 38.

Note: Bolts # 7 & 13 will only be used if you have outside grommets in your back flap.

- C. If the tarp has outside grommets in the back flap, then drill a 3/16" hole in the bow and insert the self threading screws (part # 506-0205) through the outside grommets and into the bow.

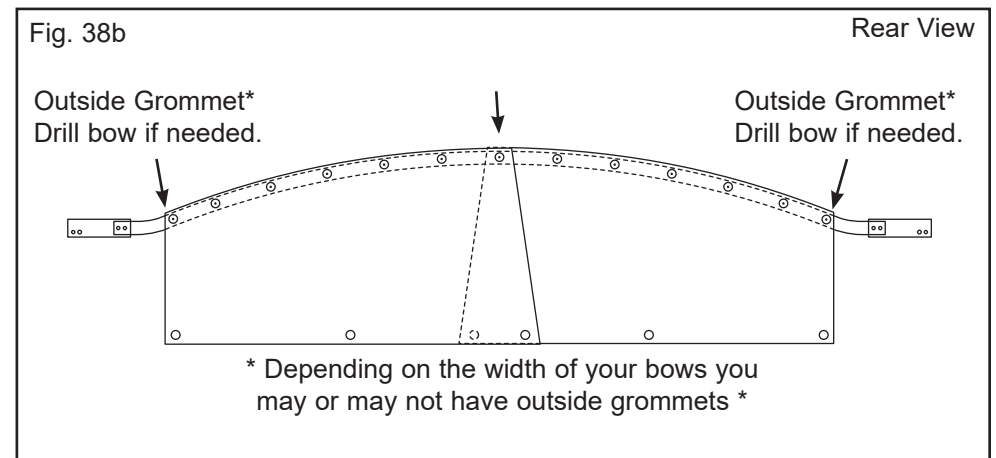
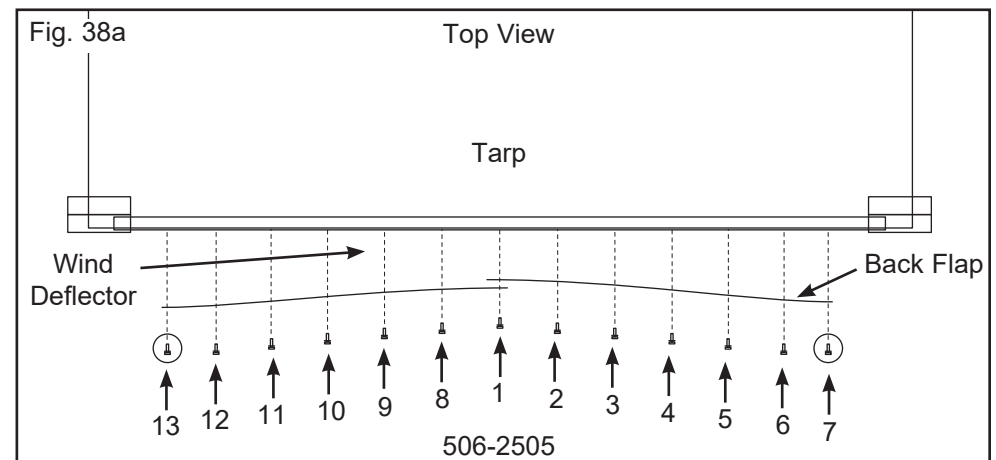
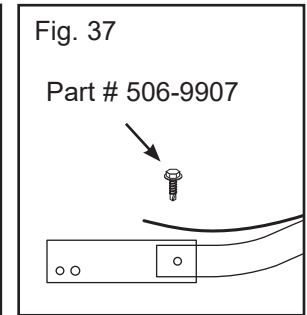
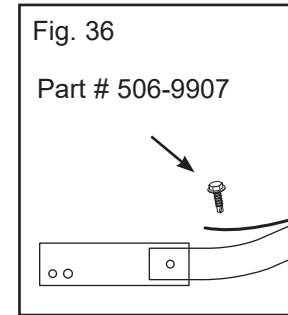
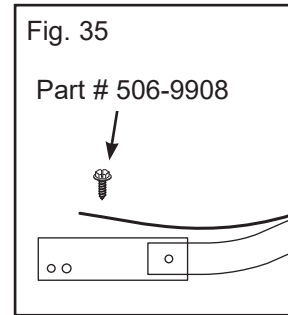
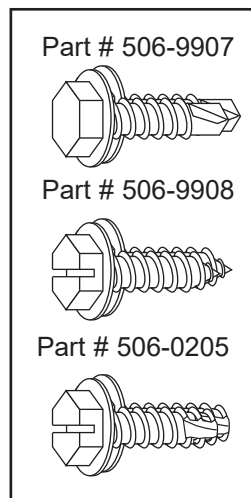

Step 23. Hold Down Hooks and Hold Down Rollers are installed every 3rd or 4th slider. Space evenly and use all hooks provided. Longer hooks are installed to the front (Fig 39 & 40).

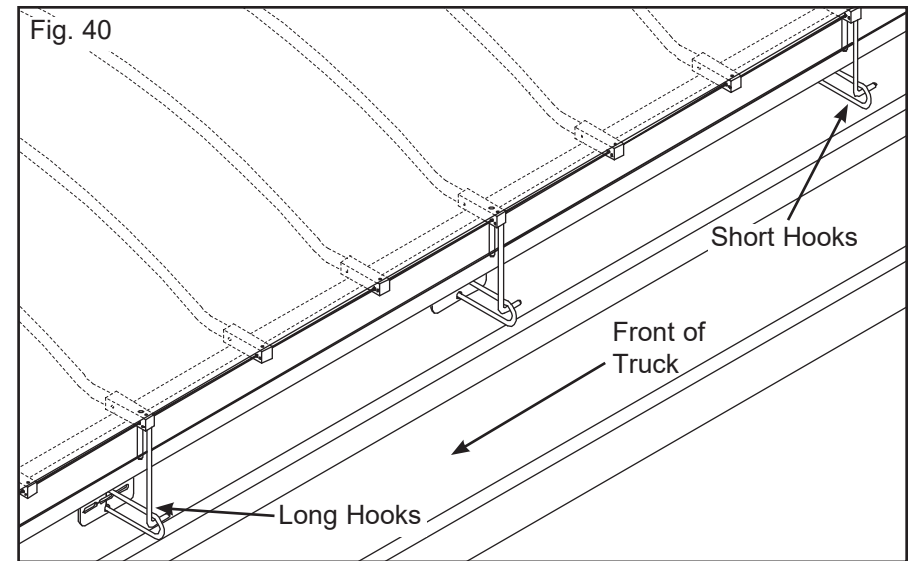
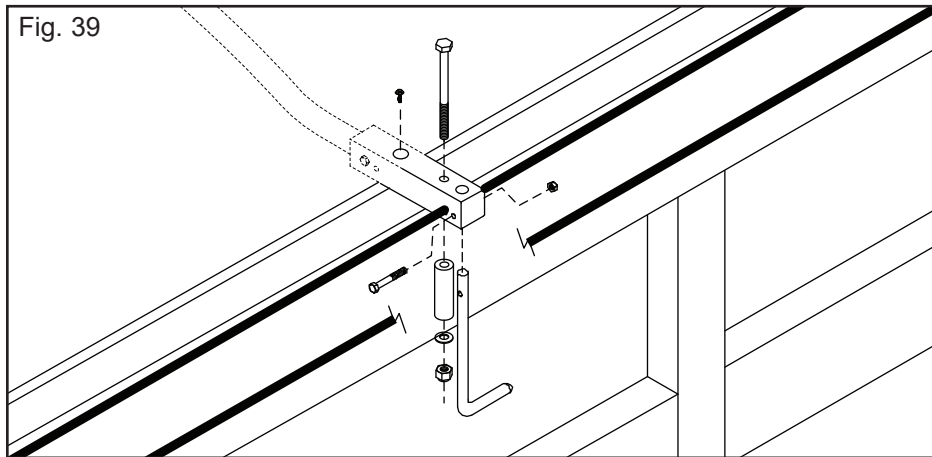

Step 24. On steel bodies cut Body Hold Downs to allow 1" clearance between Slider Hold Down Hooks and Body Hold Downs (Fig. 43).

Step 25. On steel bodies weld Body Hold Downs in place (Fig. 45).

Step 26. On aluminum bodies Cut Body Hold Downs to allow 1" clearance between Slider Hold Down Hooks and Body Hold Downs (Fig. 44) . Weld to mounting plate then bolt to body (Fig. 46).

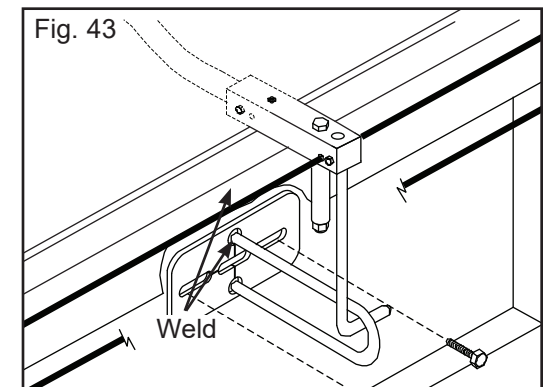
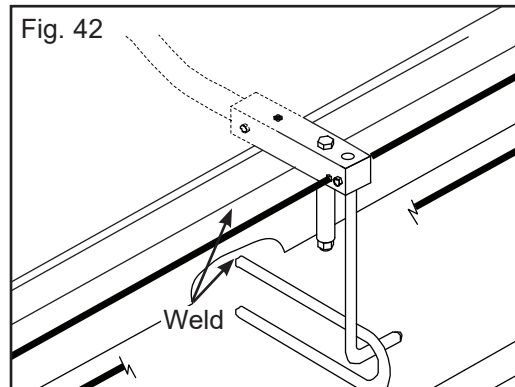
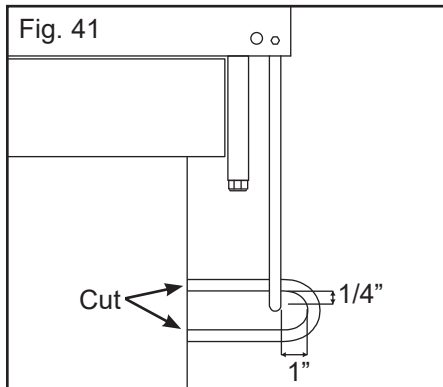

Final Testing of System

Step 27.
Cycle system in and out a few times. Add cable tension until the cable begins to slip on the drive pulley when the system is fully retracted, then add one additional full turn.

Step 28.
Check slider distance to rear pulleys as shown in Step 16. Recheck cable tension often during the first week of operation. Adjust cable tension and realign bows as needed.

Single Cable Hand Crank Drive Kit - Standard (Part # 502-0501) Single Cable Hand Crank Drive Kit - with Idler Pulley (Part # 502-0502) Crank Base Mount Assembly - Ordered Separately (Part # 502-0509)

HAND CRANK DRIVE KITS - PART # 502-0501 & 502-0502

ITEM	PART#	DESCRIPTION	QTY
1	502-0508	CRANK ARM ASSEMBLY - INCLUDES ITEM 2	1
2	502-0567	SPRING LOCK PLUNGER	1
3	502-0512	HAND CRANK DRIVE COVER ASSY.	1
4	502-0533	4.5" DRIVE PULLEY "V" GROOVE W/BEARING	1
5	505-9905	20mm FLAT WASHER	2
6	504-9902	20mm NYLOC NUT	1
7	503-3103	5/16"-18 x 3/4"lg. HHCS BOLT	2
8	505-3102	5/16" LOCK WASHER	2
WITH IDLER PULLEY #502-0502			
9	502-0148	2.5" PULLEY W/BEARING	1
10	506-5003	1/2"-13 x 1"lg. FLAT HEAD SOCKET CAP	1
11	505-9905	20mm FLAT WASHER	1
12	502-0564	PULLEY HANDLE SPACER	1

CRANK BASE MOUNT ASSEMBLY - PART # 502-0509

ITEM	PART#	DESCRIPTION	QTY
13	505-5001	1/2" AN FLAT WASHER	4
14	506-1201	1/8" x 1" COTTER PIN	2
15	502-0510	CRANK BASE PLATE ASSEMBLY	1
16	502-0516	CRANK ADJ. SHAFT, 1/2"-13 x 14"lg. THREADED	1
17	502-0530	1/2" GUIDE SHAFT 13 1/4"lg.	1
18	504-5004	1/2"-13 NYLOC NUT	2
19	504-5005	1/2"-13 HEX NUT	1

BAB REV. 11/21/07

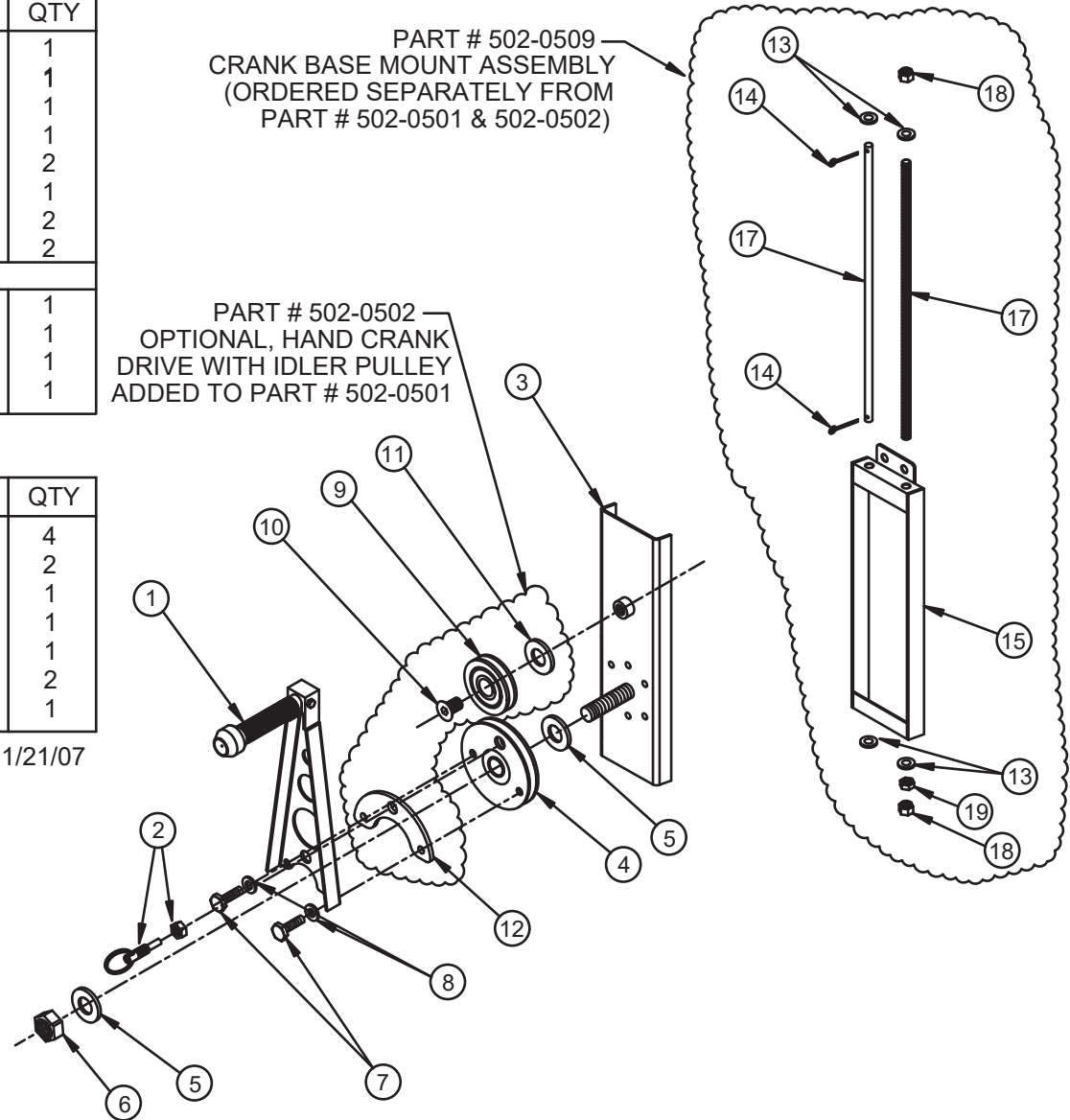

Single Cable Standard Motor Drive Assembly (Part # 502-0601) Crank Base Mount Assembly - Ordered Separately (Part # 502-0509)

STANDARD MOTOR DRIVE ASSEMBLY - PART # 502-0601

ITEM	PART#	DESCRIPTION	QTY
1	504-3103	5/16"-18 NYLOC NUT	4
2	517-0906	12V DC ELECTRIC MOTOR	1
3	503-3103	5/16"-18 x 3/4"lg HHCS BOLT	3
4	517-0326	.312 x 1.5"lg. DOWEL PIN	1
5	502-0620	SUPER WINCH MOTOR BRACKET	1
6	502-0621	4.5" SUPER WINCH "V" PULLEY	1
7	502-0635	SWMOTOR DRIVE COVER ASSEMBLY	1
8	505-3102	5/16" LOCK WASHER	3
*	514-0121	6 GA. ELECTRICAL WIRE	70'
*	514-0505	QUICK DISCONNECT TERM 50 AMP	2
*	514-0114	SMART SWITCH BASIC KIT	1

CRANK BASE MOUNT ASSEMBLY - PART # 502-0509

ITEM	PART#	DESCRIPTION	QTY
9	505-5001	1/2" AN FLAT WASHER	4
10	506-1201	1/8" x 1" COTTER PIN	2
11	502-0510	CRANK BASE PLATE ASSEMBLY	1
12	502-0516	CRANK ADJ. SHAFT, 1/2"-13 x 14"lg. THREADED	1
13	502-0530	1/2" GUIDE SHAFT 13 1/4"lg.	1
14	504-5004	1/2"-13 NYLOC NUT	2
15	504-5005	1/2"-13 HEX NUT	1

* NOT SHOWN *

BAB REV. 11/20/07

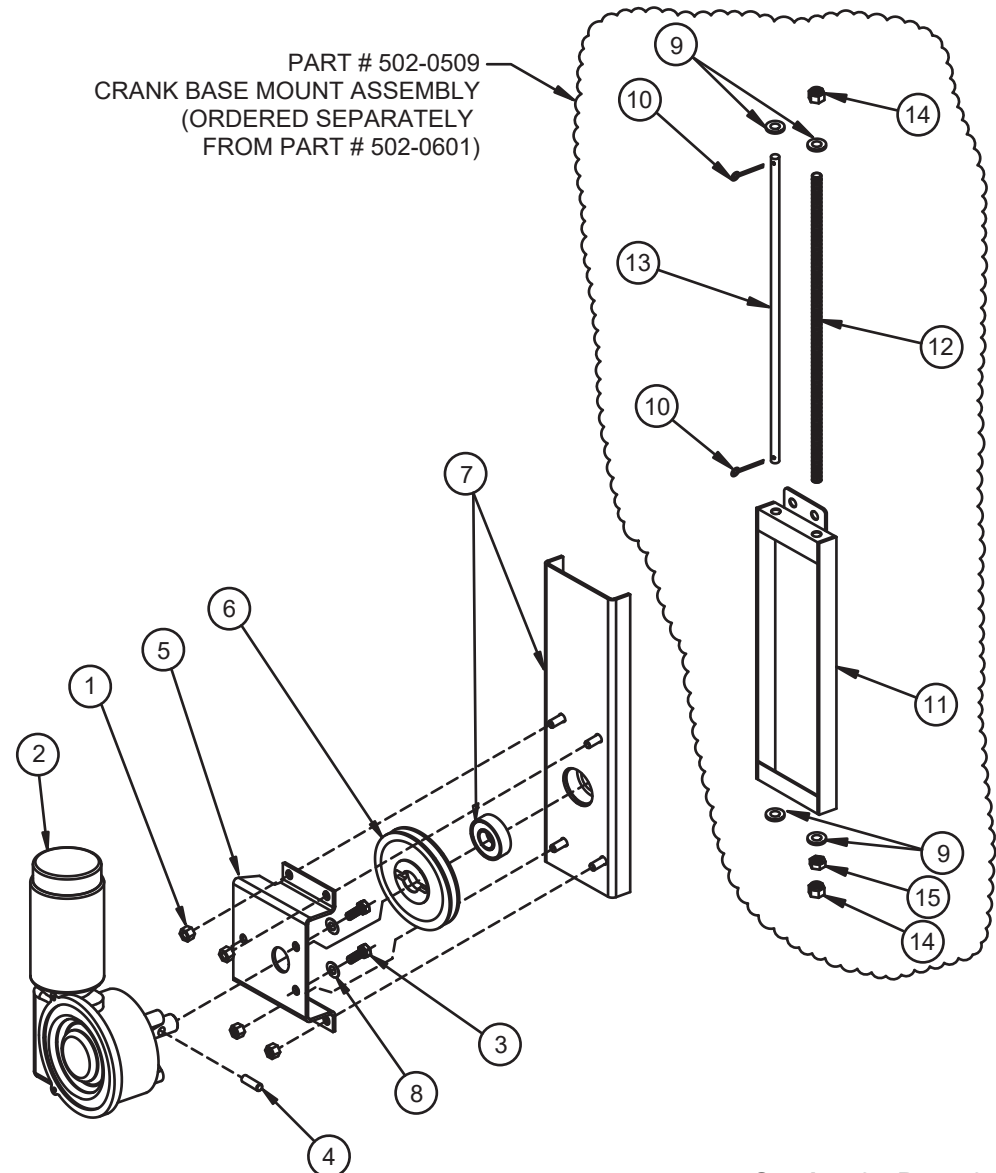

Single Cable Gear Reduction Motor Drive Assembly (Part # 502-0602) Crank Base Mount Assembly - Ordered Separately (Part # 502-0509)

GEAR REDUCTION MOTOR DRIVE ASSEMBLY - PART # 502-0602

ITEM	PART#	DESCRIPTION	QTY
1	502-0546	1-1/8 PULLEY BUSHINGS	2
2	502-0561	GEAR DRIVE MOTOR MOUNT	1
3	502-0570	24 TOOTH GEARED PULLEY	1
4	505-3102	5/16" LOCK WASHER	9
5	503-3103	5/16 -18 x 1" HHCS	3
6	503-3101	5/16 - 18x 1/2 " HHCS	6
7	503-5007	1/2" - 13 x 2-1/4" HHCS	1
8	505-5003	1/2" AN LOCK WASHER	1
9	517-0326	DIA. 0.312 x 1.5" DOWEL PIN	1
10	502-0592	ADJUSTABLE MOTOR COVER ASSY W/BEARING	1
11	502-0573	37 TOOTH GEARED PULLEY W/BEARINGS	1
12	517-0906	12V DC ELECTRIC MOTOR	1
*	514-0123	6 GA. ELECTRICAL WIRE	90'
*	514-0505	QUICK DISCONNECT TERM 50 AMP	2
*	514-0114	SMART SWITCH BASIC KIT	1

CRANK BASE MOUNT ASSEMBLY - PART # 502-0509

ITEM	PART#	DESCRIPTION	QTY
13	505-5001	1/2" AN FLAT WASHER	4
14	506-1201	1/8" x 1" COTTER PIN	2
15	502-0510	CRANK BASE PLATE ASSEMBLY	1
16	502-0516	CRANK ADJ. SHAFT, 1/2"-13 x 14"lg. THREADED	1
17	502-0530	1/2" GUIDE SHAFT 13 1/4"lg.	1
18	504-5004	1/2"-13 NYLOC NUT	2
19	504-5005	1/2"-13 HEX NUT	1

* NOT SHOWN *

BAB 11/21/07

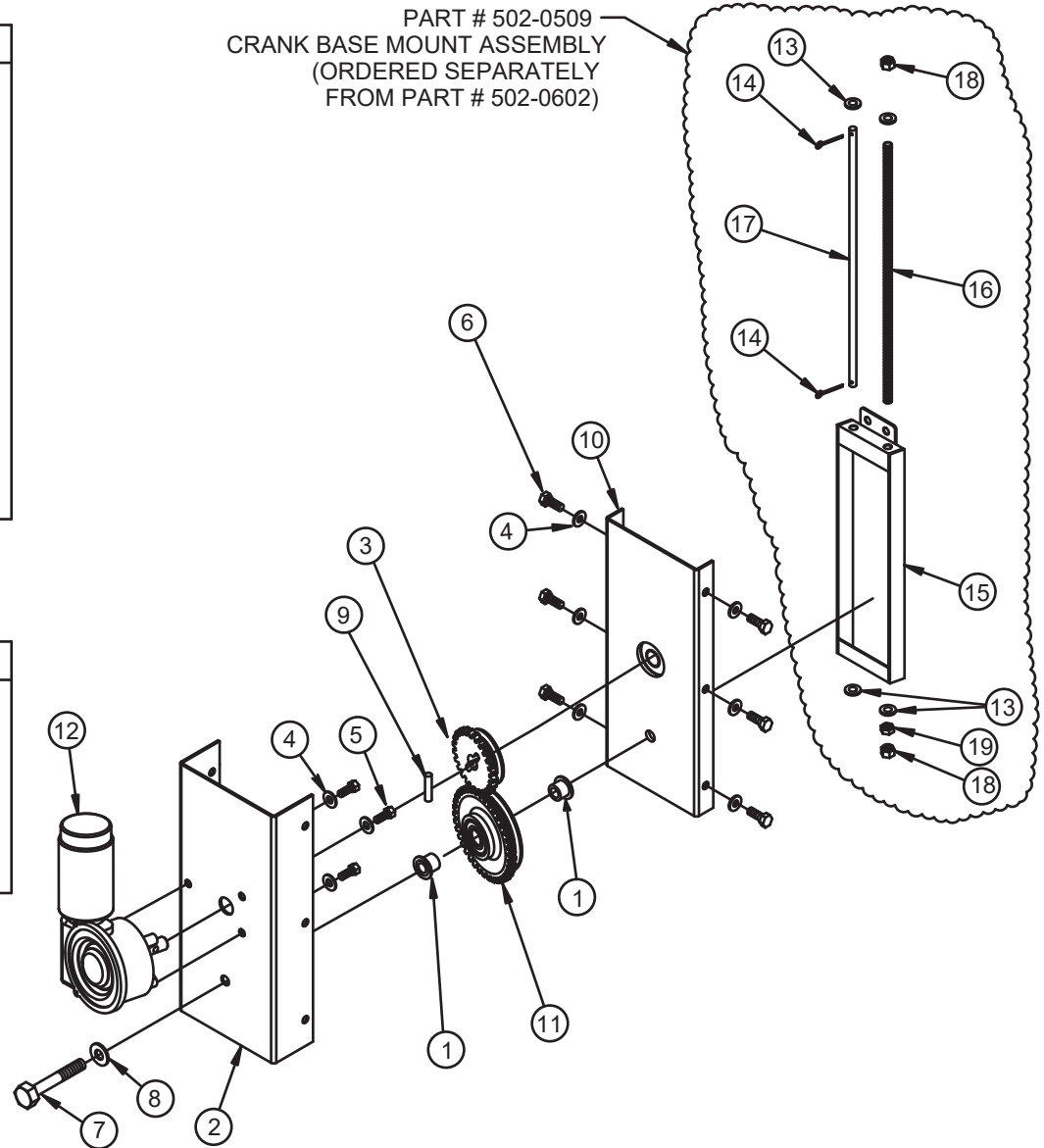

Single Cable Rear Pulley Mount Assembly (Part # 502-0201)

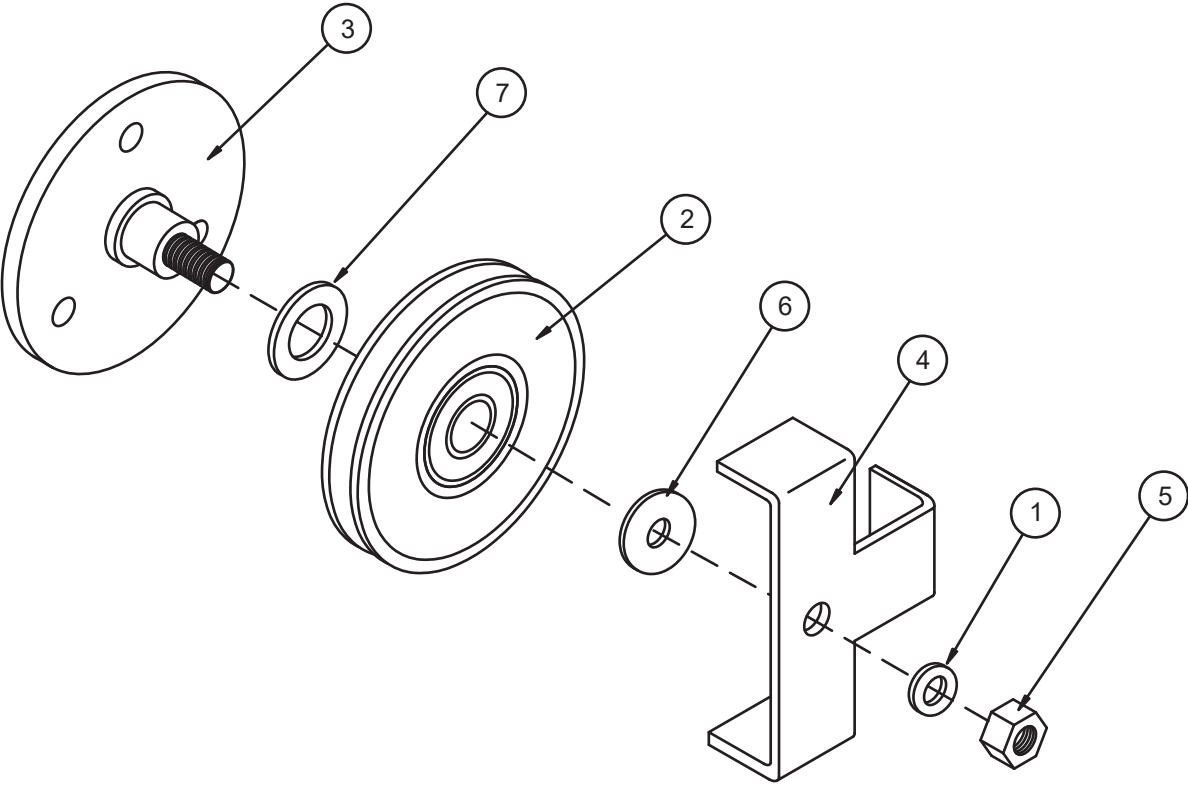

ITEM	PART#	DESCRIPTION	QTY
1	505-5001	1/2" AN FLAT WASHER	1
2	502-0208	4.5" STANDARD PULLEY W/BEARING	1
3	502-0210	REAR PULLEY MOUNT	1
4	502-0213	REAR PULLEY MOUNT COVER	1
5	504-5004	1/2"-13 NYLOC NUT	1
6	505-5004	1/2" FLAT WASHER USS	1
7	505-9905	20mm FLAT WASHER	1

BAB REV. 11/21/07

Top Sliders Hold Down Assembly (Part # 502-0007)

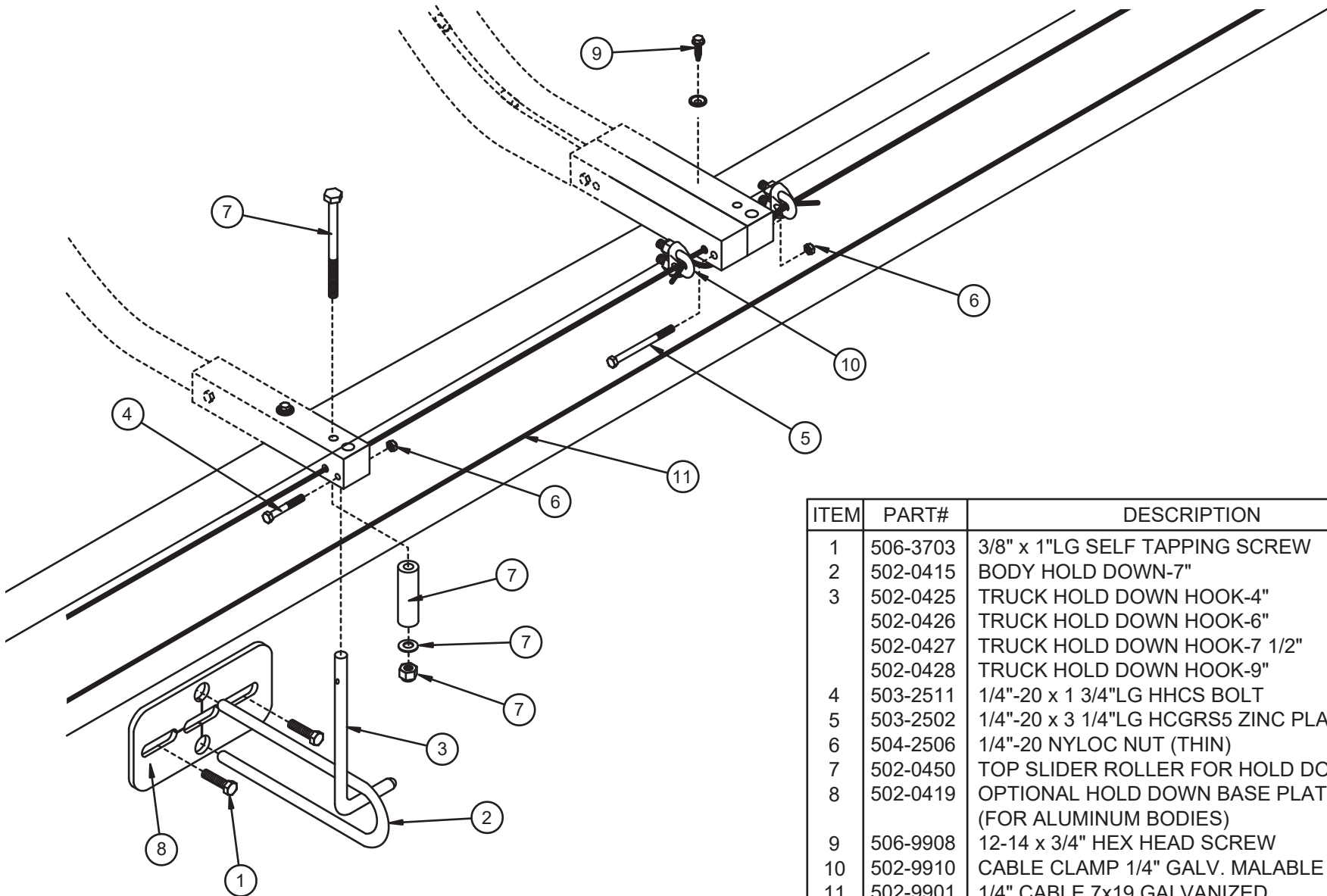

ITEM	PART#	DESCRIPTION	QTY
1	506-3703	3/8" x 1"LG SELF TAPPING SCREW	***
2	502-0415	BODY HOLD DOWN-7"	***
3	502-0425	TRUCK HOLD DOWN HOOK-4"	***
	502-0426	TRUCK HOLD DOWN HOOK-6"	***
	502-0427	TRUCK HOLD DOWN HOOK-7 1/2"	***
	502-0428	TRUCK HOLD DOWN HOOK-9"	***
4	503-2511	1/4"-20 x 1 3/4"LG HHCS BOLT	***
5	503-2502	1/4"-20 x 3 1/4"LG HCGRS5 ZINC PLATED	2
6	504-2506	1/4"-20 NYLOC NUT (THIN)	***
7	502-0450	TOP SLIDER ROLLER FOR HOLD DOWN	***
8	502-0419	OPTIONAL HOLD DOWN BASE PLATE (FOR ALUMINUM BODIES)	***
9	506-9908	12-14 x 3/4" HEX HEAD SCREW	***
10	502-9910	CABLE CLAMP 1/4" GALV. MALABLE	***
11	502-9901	1/4" CABLE 7x19 GALVANIZED	

BAB REV. 12/8/07

*** QUANTITIES VARY DEPENDING ON LENGTH***

Single Cable Optional Side Pulley Box Assembly (Part # 502-0108)

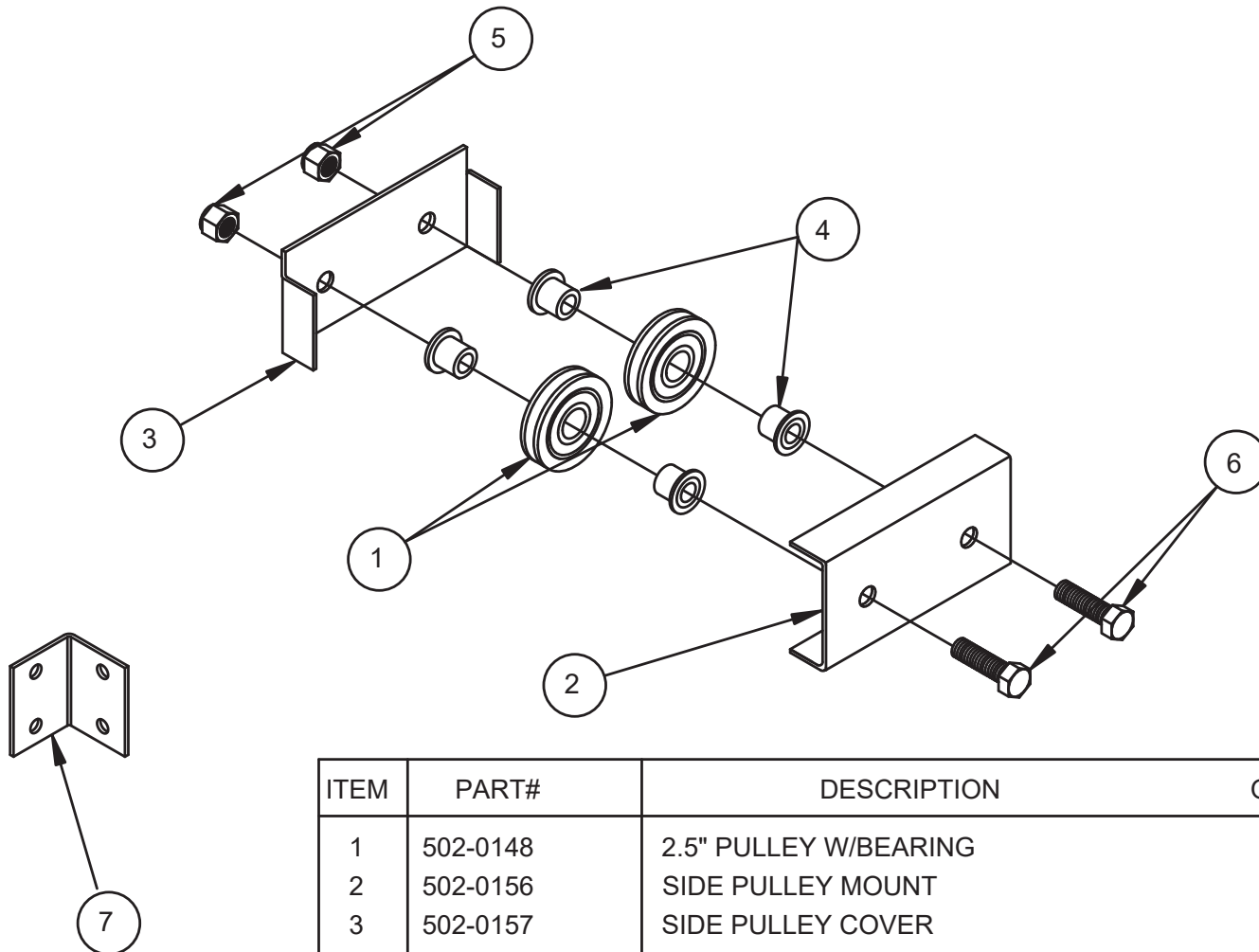

ITEM	PART#	DESCRIPTION	QTY
1	502-0148	2.5" PULLEY W/BEARING	2
2	502-0156	SIDE PULLEY MOUNT	1
3	502-0157	SIDE PULLEY COVER	1
4	502-0159	BUSHING, PULLEY 20mm (ALUMINUM)	4
5	504-5004	1/2"-13 NYLOC NUT	2
6	503-5014	1/2"-13 x 1 3/4"lg. HHCS BOLT	2
7	502-0451	SLIDER BRACKET	2

Single Cable Top Slider Front Cover Assembly (Part # 502-0184) and Associated Parts

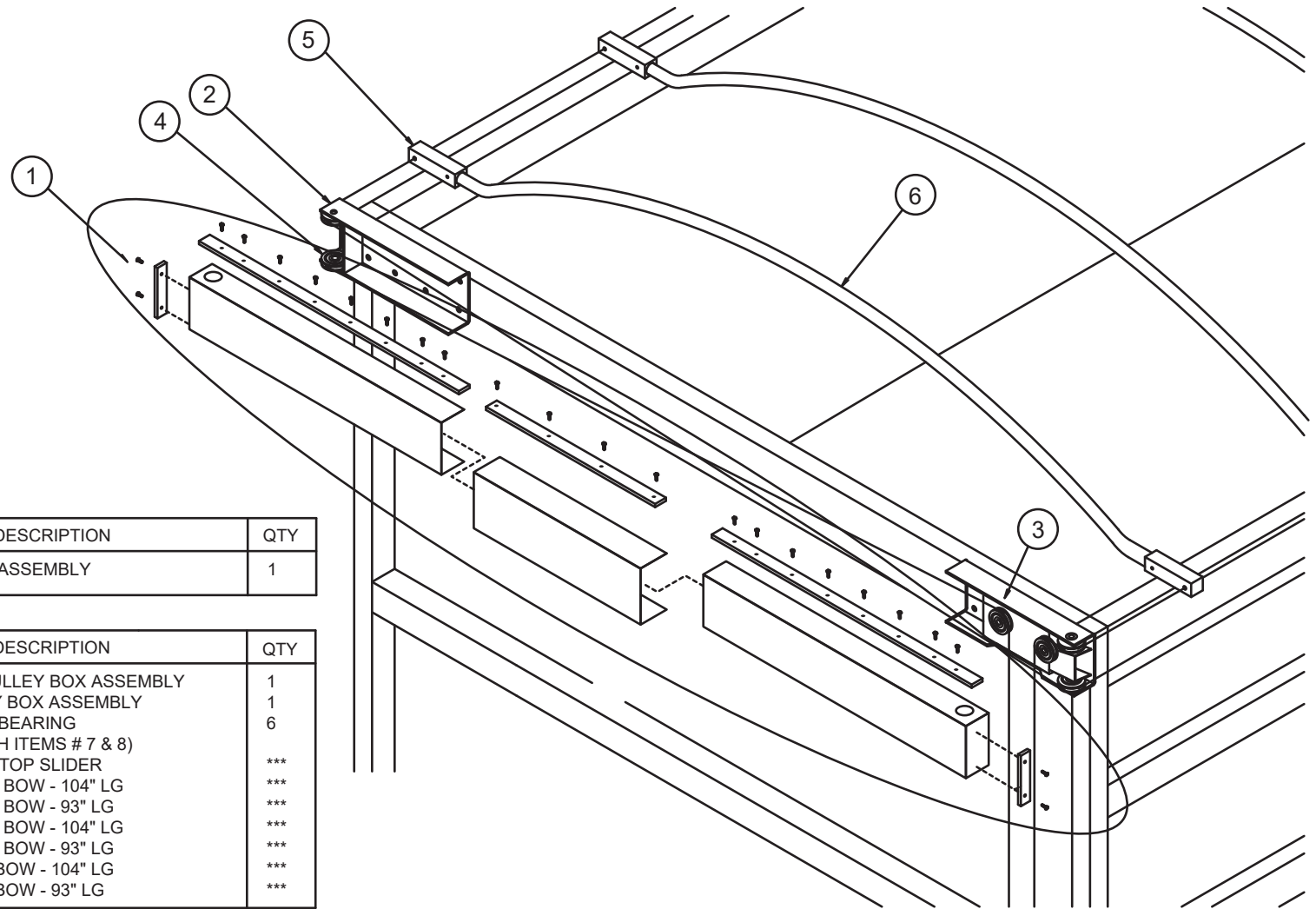

FRONT COVER ASSEMBLY

ITEM	PART#	DESCRIPTION	QTY
1	502-0184	FRONT COVER ASSEMBLY	1

ASSOCIATED PARTS

ITEM	PART#	DESCRIPTION	QTY
2	502-0107	PASSENGER PULLEY BOX ASSEMBLY	1
3	502-0105	DRIVER PULLEY BOX ASSEMBLY	1
4	502-0148	2.5" PULLEY W/ BEARING (INCLUDED WITH ITEMS # 7 & 8)	6
5	502-0304	8" HOLD DOWN TOP SLIDER	***
6	502-0326	16" TOP SLIDER BOW - 104" LG	***
	502-0327	16" TOP SLIDER BOW - 93" LG	***
	502-0321	12" TOP SLIDER BOW - 104" LG	***
	502-0323	12" TOP SLIDER BOW - 93" LG	***
	502-0322	6" TOP SLIDER BOW - 104" LG	***
	502-0324	6" TOP SLIDER BOW - 93" LG	***

REAR BOWS (NOT SHOWN)

ITEM	PART#	DESCRIPTION	QTY
	502-0326	16" TOP SLIDER BOW - 104" LG	***
	502-0327	16" TOP SLIDER BOW - 93" LG	***
	502-0321	12" TOP SLIDER BOW - 104" LG	***
	502-0323	12" TOP SLIDER BOW - 93" LG	***
	502-0322	6" TOP SLIDER BOW - 104" LG	***
	502-0324	6" TOP SLIDER BOW - 93" LG	***

REV NB 1/6/11

*** QUANTITIES VARY DEPENDING ON LENGTH ***

Top Slider Rear Air Gate Bow Assembly (Part # 502-0403)

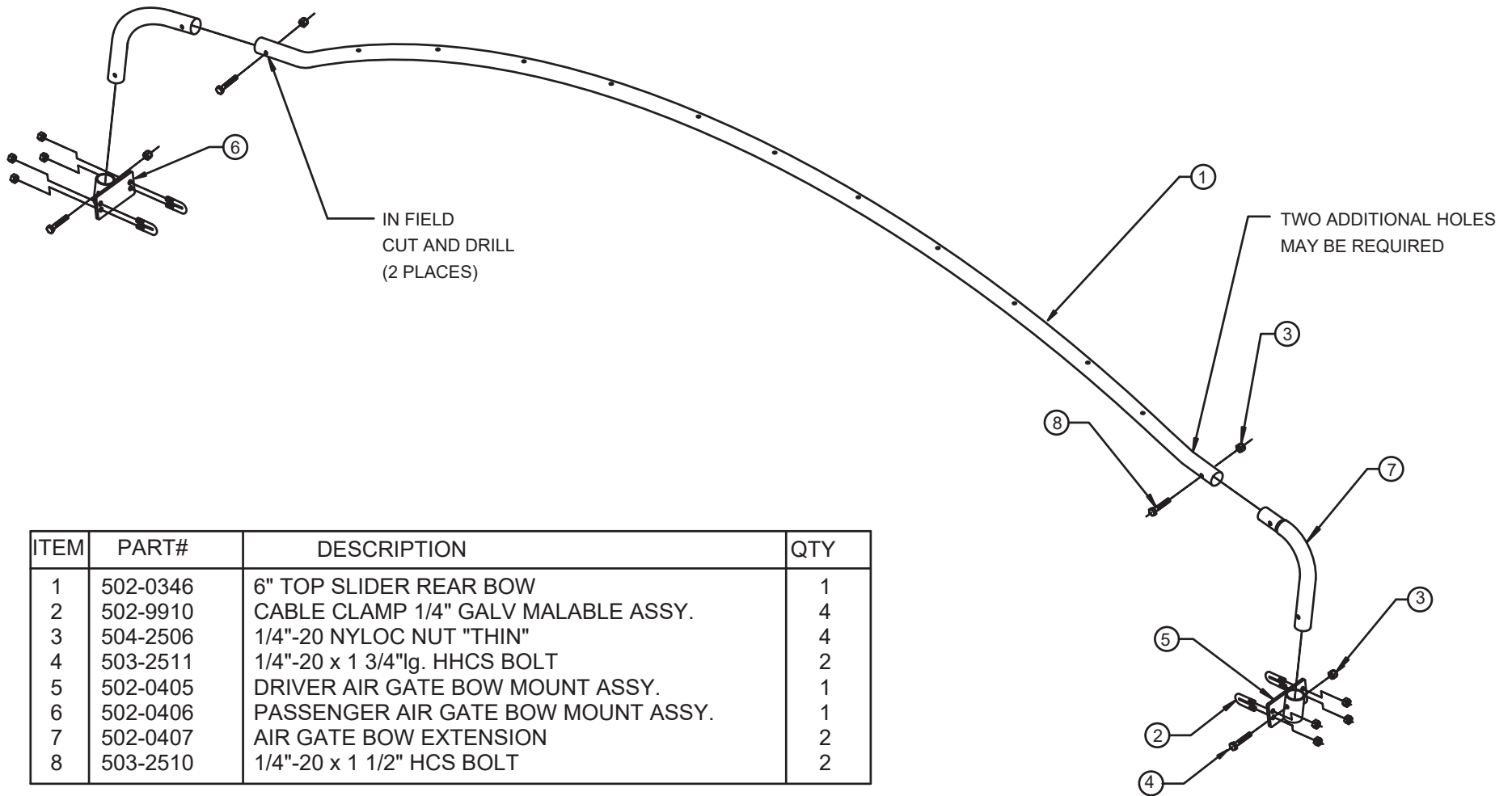

NB REV: 3/18/10

Top Slider Air Gate Bow Assembly (Part # 502-0404)

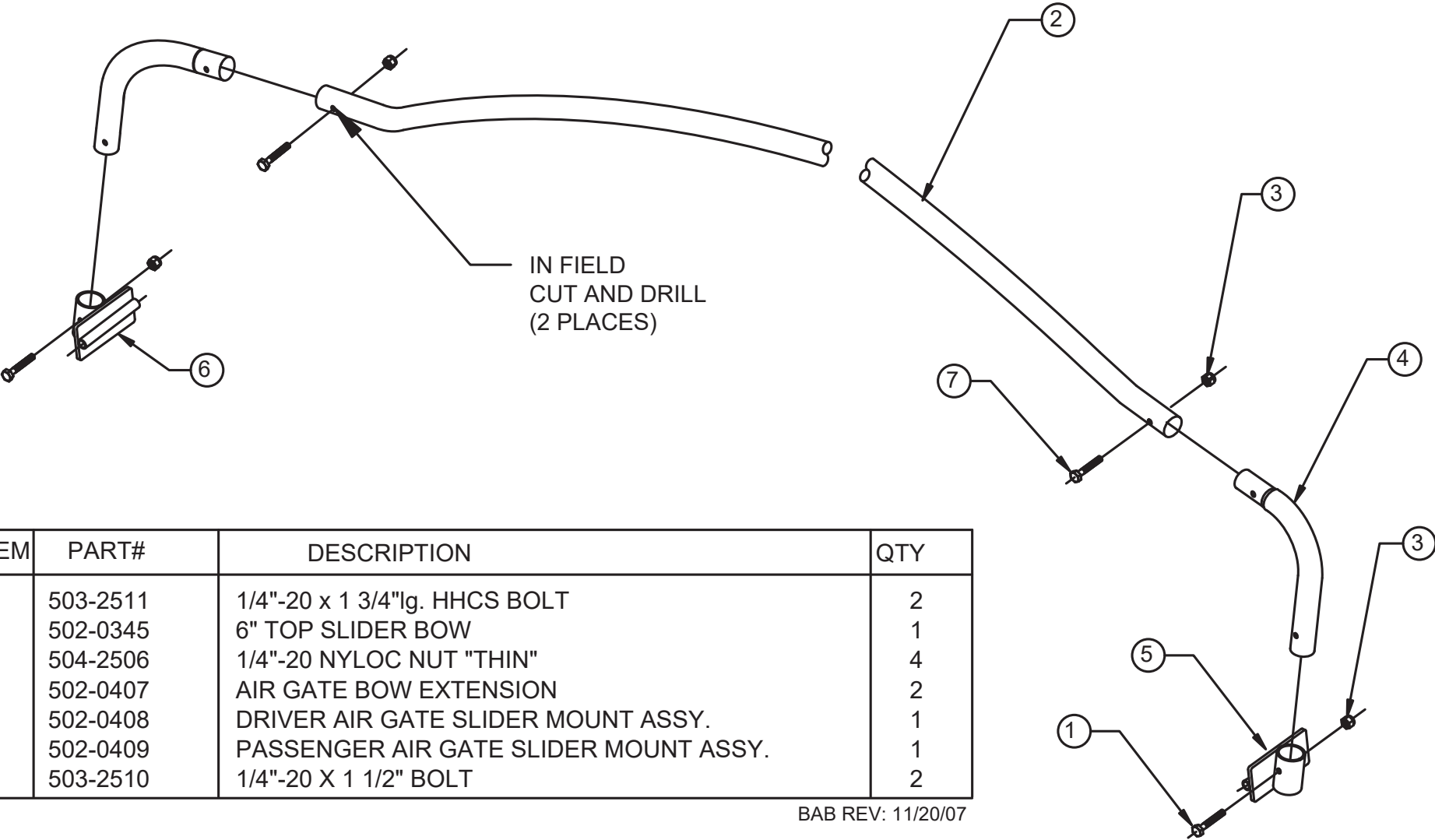

ITEM	PART#	DESCRIPTION	QTY
1	503-2511	1/4"-20 x 1 3/4"lg. HHCS BOLT	2
2	502-0345	6" TOP SLIDER BOW	1
3	504-2506	1/4"-20 NYLOC NUT "THIN"	4
4	502-0407	AIR GATE BOW EXTENSION	2
5	502-0408	DRIVER AIR GATE SLIDER MOUNT ASSY.	1
6	502-0409	PASSENGER AIR GATE SLIDER MOUNT ASSY.	1
7	503-2510	1/4"-20 X 1 1/2" BOLT	2

BAB REV: 11/20/07

Smart Switch Basic Kit (Part # 514-0114)

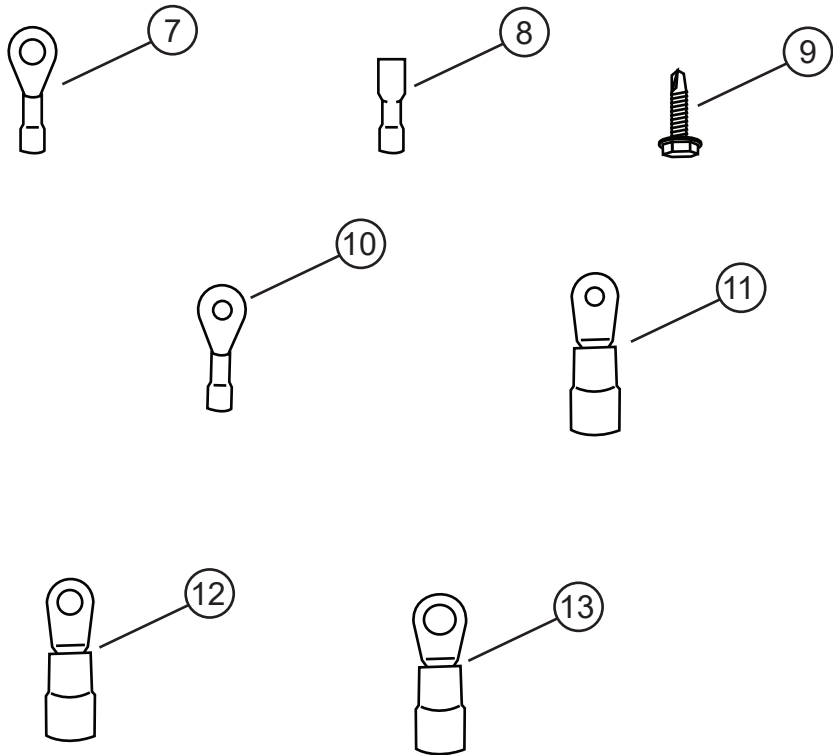
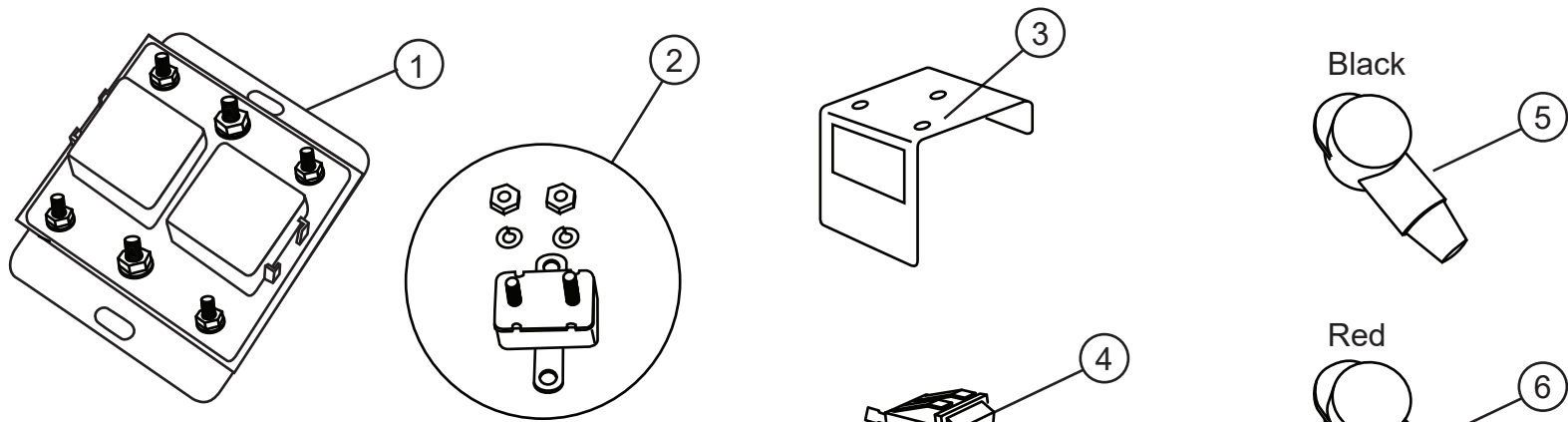

Item #	Part #	Description:	QTY:
1	514-9967	Reversing Polarity 12v Solenoid	1
2	514-0408	50 Amp Type II Breaker	1
3	514-9954	Rocker Switch Bracket	1
4	514-0117	Rocker Switch 3 Position Momentary	1
5	514-0337	Black Terminal Boot	2
6	514-0336	Red Terminal Boot	2
7	514-0304	Connector 14 ga. Lug with 1/4" Eyelet	1
8	514-0321	Push On Female Terminal 16 ga.	3
9	506-9904	#10 x 3/4" Self Drilling Screw	6
10	514-0303	Connector 14 ga. #10 Stud Eyelet	2
11	514-0307	Connector 6 ga. #10 Stud	2
12	514-0308	Connector 6 ga. Lug with 1/4" Eyelet	6
13	514-0309	Connector 6 ga. Lug with 3/8" Eyelet	2
	514-0211	#16-3 Wire PVC 27# Copper	25 Ft.

BAB REV. 1/23/09