



A Safe Fleet Brand

Roll Rite, LLC and its entire staff would like to not only Thank You but congratulate you on your purchase of one of what we feel to be the finest line of tarping systems in the industry.

Side to Side Lock Down Tarping System

(Single & Dual Arm - Driver & Pass. Stowing)

RR Part # 101625

Questions? Contact Customer Service @ 800-297-9905

Or

Parts Diagrams see "Parts and Diagrams" section on web at www.rollrite.com

In this booklet you will find:

INSTALLATION INSTRUCTIONS	3
ALUMINUM END CAP INSTALLATION.....	3
SPRING BOW SIZING.....	5
SPRING BOW INSTALLATION.....	6
LOCKING LIP INSTALLATION.....	8
TARP TUBE LOCK INSTALLATION.....	8
RUB RAIL INSTALLATION.....	8
PIVOT INSTALLATION.....	9
FRONT ARM ASSEMBLY.....	9
REAR ARM INSTALLATION (FOR DUAL ARM SYSTEMS).....	13
<i>Knuckle Arm</i>	13
<i>Flex Arm</i>	16
TARP ASSEMBLY.....	17
WIRING THE SYSTEM.....	22
PIVOT INSTALLATION SECTION.....	23
<i>Standard Pivot Mount Installation</i>	24
<i>Grain Trailer Mount Installation</i>	25
<i>Adjustable Grain Trailer Mount</i>	27
<i>Catwalk Mount Roller Bearing Pivot</i>	28
<i>Catwalk Mount External Style Pivot</i>	28
<i>Universal External Pivot Mount</i>	29
<i>Multi-Flex Pivot Mount</i>	32
OPERATING MANUAL	35
MAINTENANCE MANUAL	36

Installation Instructions

Aluminum End Cap Installation

Note: Before you start installing your end caps, measure the tarp length. After the end caps are installed, the measurement from the outside edge of the front cap to the outside edge of the rear cap should be 3" shorter than the tarp length.

1. Place an end cap near the front of the trailer and push it forward as far as it will go.
It will stop when the legs hit the beginning of the radii or the front of the trailer. Make sure it is square to the front of the trailer.
2. Place the other end cap near the back of the trailer.
3. Subtract 3" from the tarp length. That is the distance you need from the front edge of the front end cap to the back edge of the back end cap.
(Refer to figure 1)

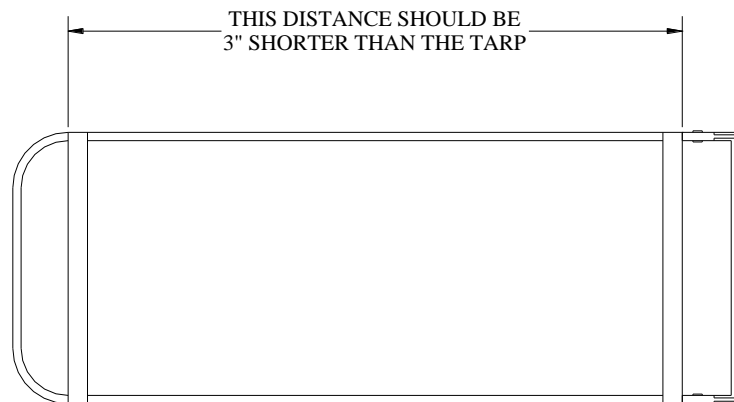

Figure 1.

4. Bolt or rivet the end caps in place by using the legs on the caps as anchors.

Front Fabric End Cap Installation

1. Locate the fabric piece to be used as the front cover. The front will not have a pocket in it.
2. Spray the rope groove in the end cap with glass cleaner or a spray lubricant.

Questions? Contact Customer Service @ 800-297-9905

Or

Parts Diagrams see "Parts and Diagrams" section on web at www.rollrite.com

3. Slide the rope into the front end cap extrusion until you have approximately the same amount of material on both sides of the trailer. If you have an asphalt tarp, make sure that the shiny side of the tarp is up when you flip it over the front of the trailer.
4. Locate the 1/8" x 1-1/4" pieces of aluminum strap that are supplied.
5. Pull the fabric tight over the front of the trailer and place the strap horizontally over the fabric. Starting at the center and working your way to the edges, use the self-drilling screws supplied to secure the strap and fabric to the front of the trailer.
6. Cut the extra fabric off below the strap.

Back Fabric End Cap Installation

1. Spray the rope groove in the extrusion and slide the tarp through it as you did in steps 2 & 3 previously.
2. Pull the tarp over the top of the tailgate and let it hang. It may need to be trimmed to fit the width of you tailgate.
3. Slide a piece of the 1/8" x 1-1/4" aluminum strap thru the pocket in the end cap.
4. Drill 1/4-inch holes thru the tarp strap. These will be used to bungee the tarp to the tailgate.

Questions? Contact Customer Service @ 800-297-9905

Or

Parts Diagrams see "Parts and Diagrams" section on web at www.rollrite.com

Spring Bow Sizing

Note:

For Flat Brackets: If your body/trailer exceeds 90-1/2" inside width, you will have to fabricate mounts to bring the inside width down to at least 90-1/2". Refer to figure 1 below. If your body/trailer does not exceed 90-1/2" inside, the spring bows are cut to the proper length based upon the required measurements given to Roll-Rite Corp. by the customer.

The following steps will explain how to find the locations of your spring bows. If you need to add mounts to get the desired inside width, do so at these locations.

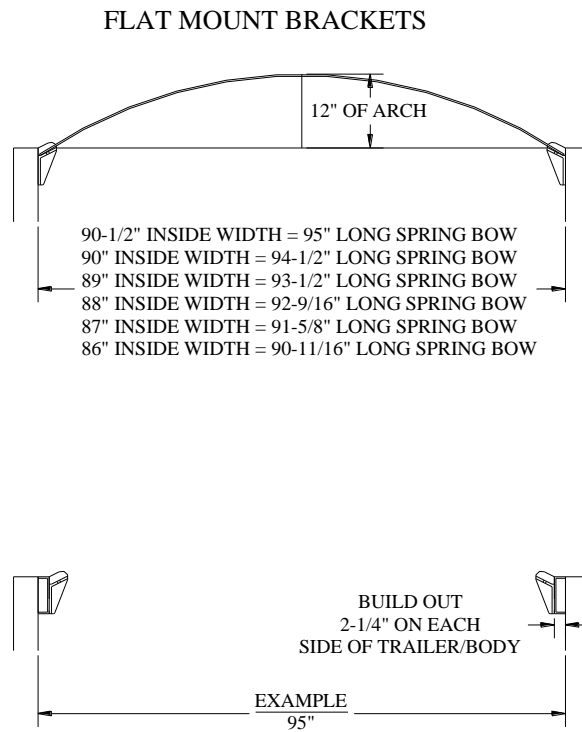

Figure 1.

Questions? Contact Customer Service @ 800-297-9905

Or

Parts Diagrams see "Parts and Diagrams" section on web at www.rollrite.com

Spring Bow Installation

1. Measure from the outside edge of the front end cap 24 inches and put a mark on each top rail. Refer to figure 2.
2. Measure from the outside edge of the rear end cap 24 inches and put a mark on each top rail. Refer to figure 2 below.

Note: The bows are placed 24" in from the end caps to prevent sag in the tarp at the front and rear of the trailer.

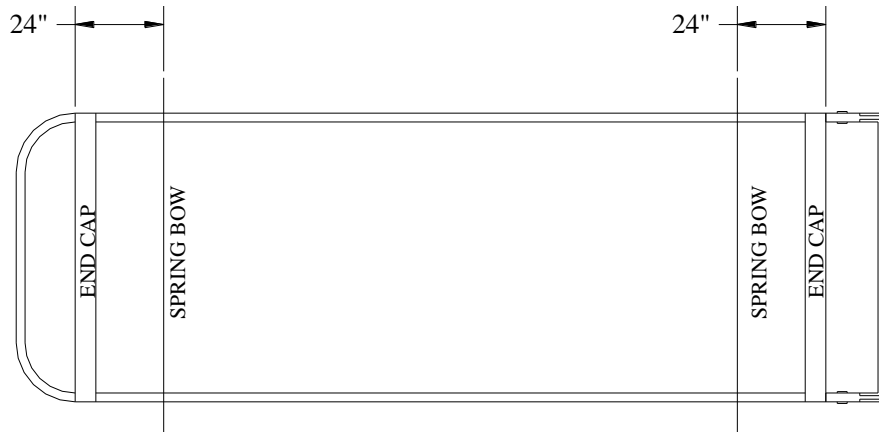

Figure 2.

3. Center a spring bow bracket on one of the marks made.

Flat Mount Spring Bow Bracket:

If you have the flat mount spring bow brackets, place the back edge flush with the top edge the box/trailer. Refer to the diagram on the left in figure 3 below.

Once in place, rivet or bolt the bracket to the box/trailer and do the same for the other three marks.

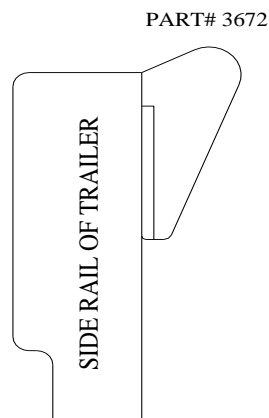

Figure 3.

Questions? Contact Customer Service @ 800-297-9905

Or

Parts Diagrams see "Parts and Diagrams" section on web at www.rollrite.com

4. Install the 2 spring bows by inserting one end at a time into the bow bracket and bolting it into place, using the 5/16 x 1-3/4" long bolts and lock nuts.

To equally space the remaining spring bows, follow the steps below.

5. Measure from the center of the front spring bow to the center of the back spring bow. Take that measurement, in inches, and divide it by the number of spring bows you have left + 1. For example, if you have 4 bows left, divide the length by 5. That will give you 5 equally spaced openings. Refer to Figure 4 below.

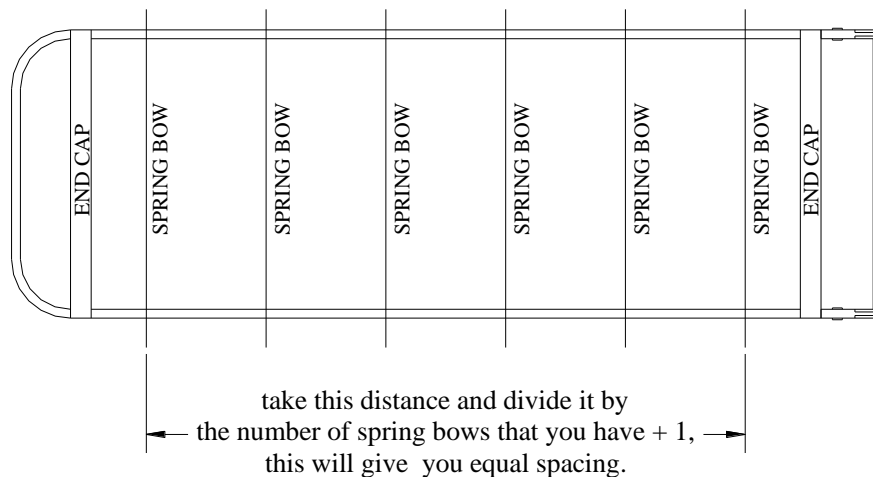

Figure 4.

6. Measure from the center of the front or back spring bow to the dimensions that were determined and mark the top rail.
7. Center the spring bow brackets on the marks made and install them the same as the front and back brackets that are already installed.
8. Install the remaining bows the same as the front and back bows that are already installed.

Questions? Contact Customer Service @ 800-297-9905

Or

Parts Diagrams see "Parts and Diagrams" section on web at www.rollrite.com

Locking Lip Installation

Note: The locking lips need to be fastened to the driver's side of the trailer.

1. Locate the aluminum locking lip extrusions.
2. The first locking lip should be positioned so that the front edge will lie 1 ½" – 2" in front of the front end cap. They should be mounted about 2" down from the top rail of the trailer.
3. Space the rest out equally or center them with the spring bows. The last lip needs to end 4" behind the back edge of the back end cap.

Tarp Tube Lock Installation

1. Locate the tarp tube locks. Refer to the parts description sheet on page 20.
2. Disassemble the hooks to reveal the holes used to mount the brackets to the trailer/body.
3. The first bracket should be positioned **no more than 2"** behind the front edge of the front end cap on the passenger side. Any more than this will allow the tarp tube to bend during lockdown. The top edge of the bracket should be mounted approximately 2" down from the top rail of the trailer.
4. Space the rest out equally or center them with the spring bows. The last bracket should end about 1 ¾" in from the back edge of the end cap. They should also be mounted 2" down from the top rail of the trailer/body.
5. Replace the plastic hook back into the aluminum bracket. Use only the bottom bolt to fasten the hook into place. The hooks need to be left open for future steps.

Rub Rail Installation

1. Locate the plastic rub rails. There are two 12" long and two 6" long.
2. The 12" rub rails should be positioned vertically just behind the front locking lip and just in front of the rear locking lip. Center the 6" pieces between the 12" pieces. Position the top of the rub rails even with the top of the locking lips.

Questions? Contact Customer Service @ 800-297-9905

Or

Parts Diagrams see "Parts and Diagrams" section on web at www.rollrite.com

Pivot Installation

Locate the pivot mounts and refer to the pivot installation section on page 23 of this booklet. Mount Pivot Mounts then continue on with arm assembly.

Front Arm Assembly

1. Locate front the knuckle arm assembly. Notice that there is a polymer bushing taped to it. Do not lose it. Refer to figure 5 for driver side stowing tarp system and figure 6 for passenger side stowing tarp system.



*Questions? Contact Customer Service @ 800-297-9905
Or
Parts Diagrams see "Parts and Diagrams" section on web at www.rollrite.com*

2. Take the short clevis pin out of the upper knuckle section. Rotate the upper section until you can get the pin back thru under the springs. Refer to step 1 in figure 5 or 6 based on system type.

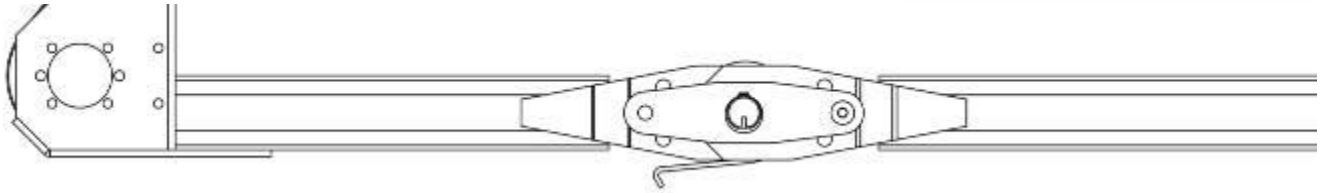

Front Arm As Shipped

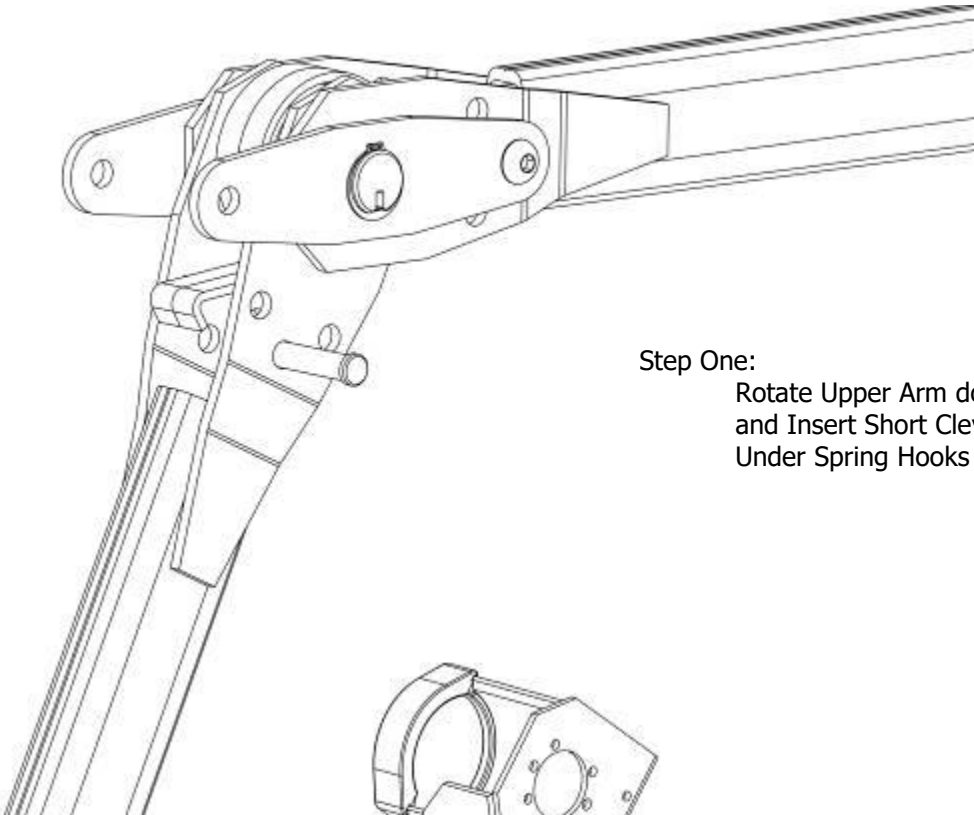

Step One:
Rotate Upper Arm down
and Insert Short Clevis Pin
Under Spring Hooks

Figure 5
Driver
Side
Stowing

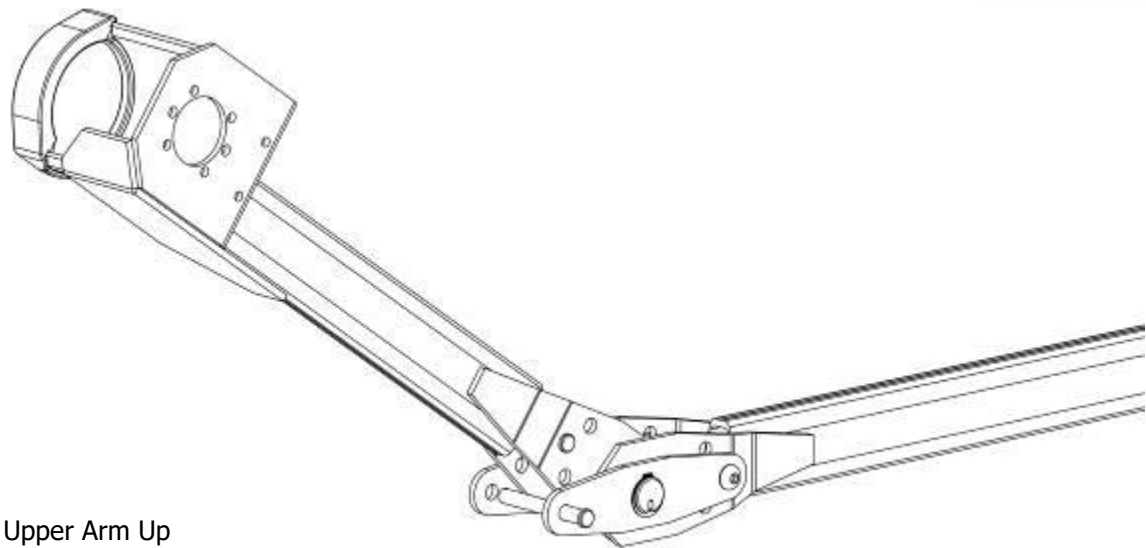

Step Two:
Rotate Upper Arm Up
and Insert Long Clevis Pin
Under Upper Arm

Questions? Contact Customer Service @ 800-297-9905
Or

Parts Diagrams see "Parts and Diagrams" section on web at www.rollrite.com

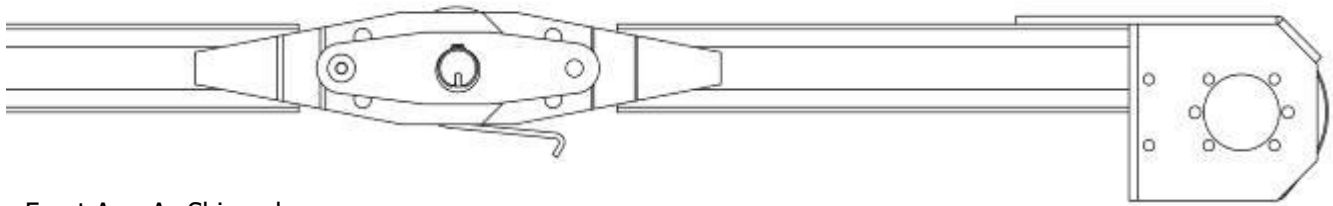

Front Arm As Shipped

Figure 6
Passenger
Side
Stowing

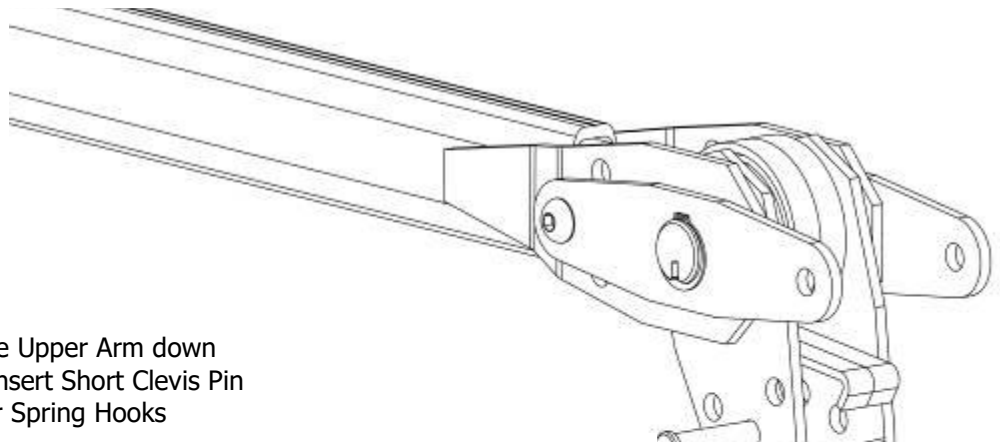

Step One:
Rotate Upper Arm down
and Insert Short Clevis Pin
Under Spring Hooks

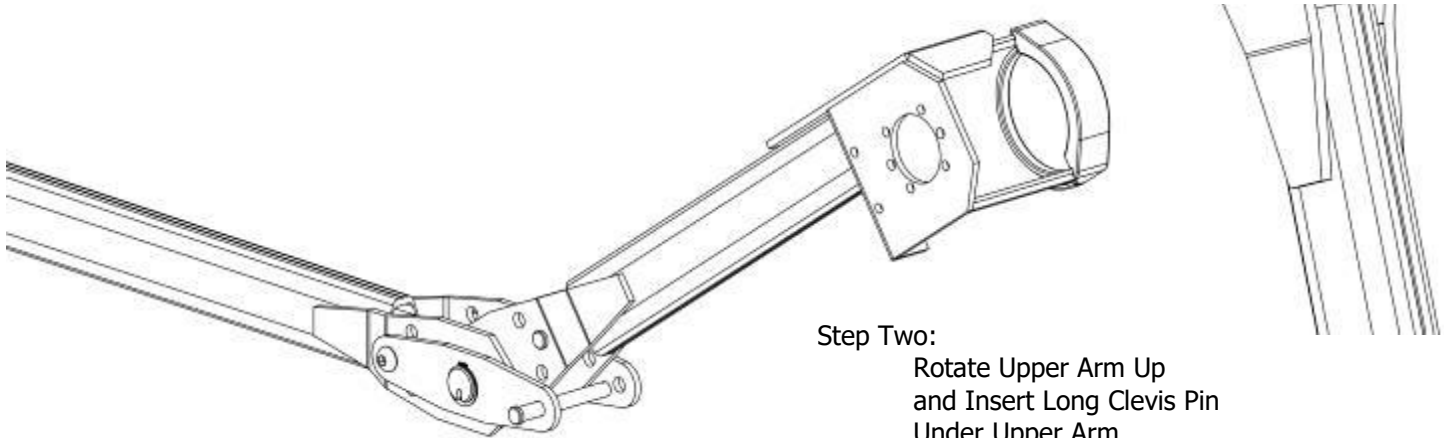

Step Two:
Rotate Upper Arm Up
and Insert Long Clevis Pin
Under Upper Arm

3. Rotate the upper arm against the spring pressure until you can get the long clevis pin thru the holes under the upper pivot tube. Refer to step 2 in figure 5 or 6.

4. Connect the arm to the pivot pin and secure with setscrews or snap ring depending on pivot type. Step 2 in figure 5 and 6 show what the arm looks like if you are looking at the front of the trailer. The pivot arm for a should mount on trailer as shown below in figure 7. Bolt gear motor on arm so that the motor tucks into the notch created by the mounting plate as shown in the figures below.

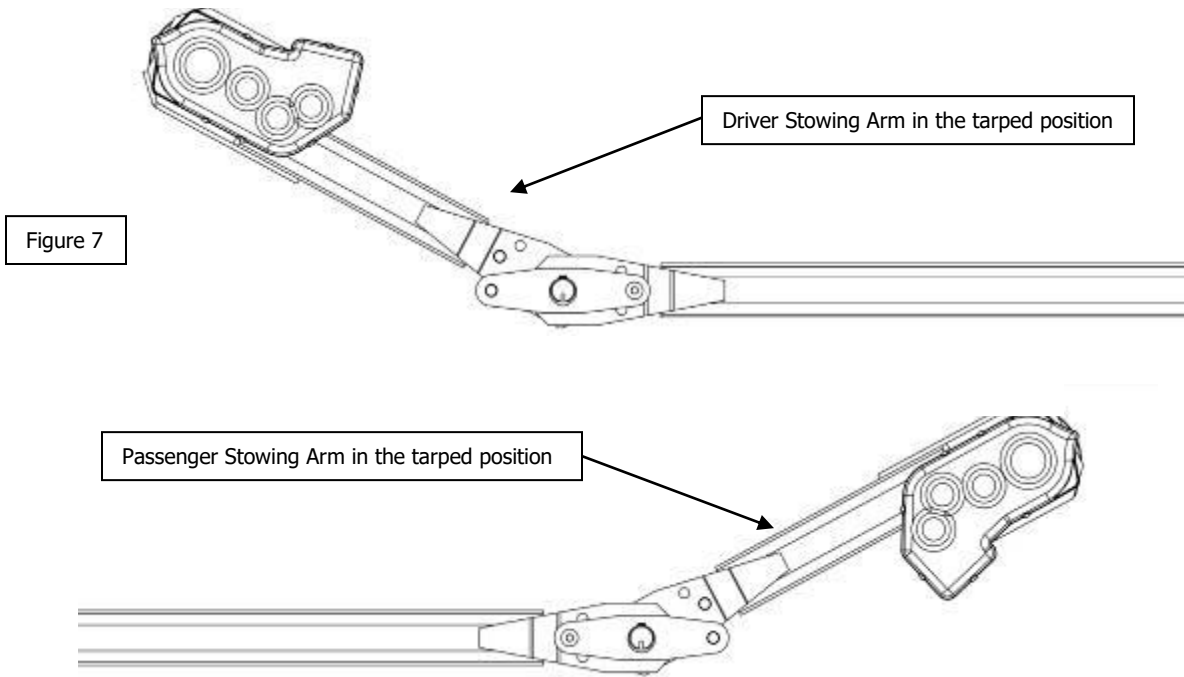

Rear Arm Installation (for Dual arm Systems)

Knuckle Arm

1. Locate the Rear knuckle arm assembly. Notice that there is a polymer bushing **bolted** to it.
2. Take the short clevis pin out of the upper knuckle section. Rotate the upper section until you can get the pin back thru under the springs. Refer to step 1 in figure 8 or 9 (on facing page) based on system type.

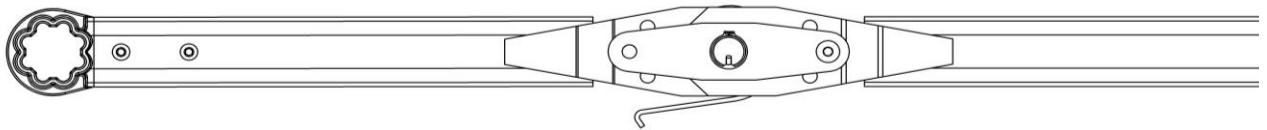

Rear Arm As Shipped

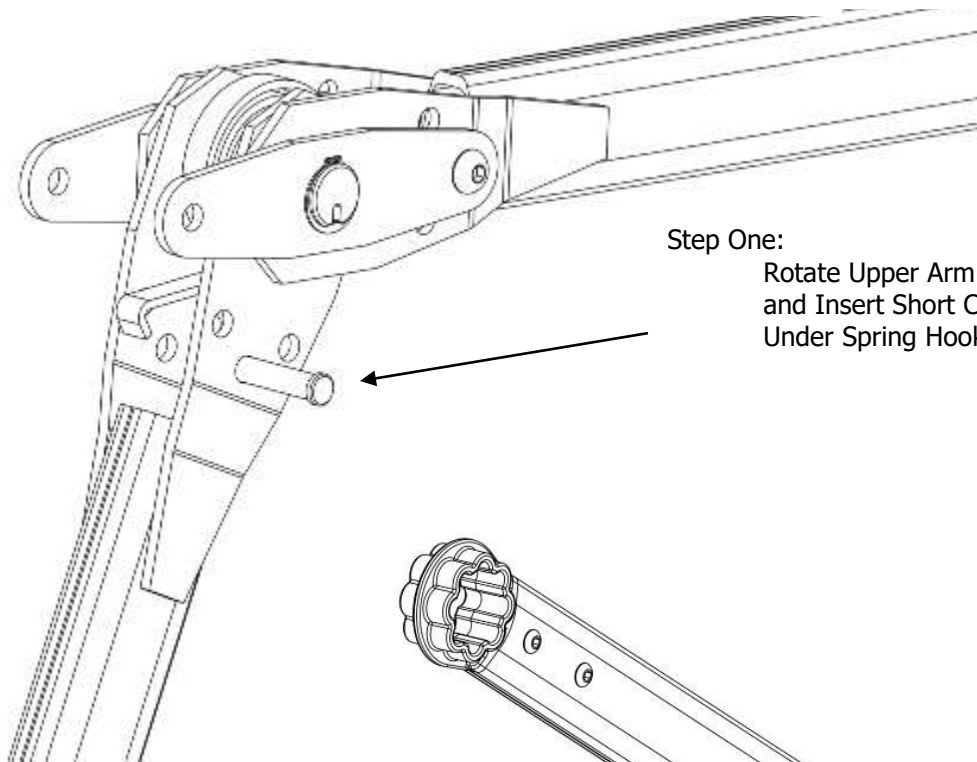

Figure 8
Driver Side
Stowing

Step One:
Rotate Upper Arm down
and Insert Short Clevis Pin
Under Spring Hooks

Step Two:
Rotate Upper Arm Up
and Insert Long Clevis Pin
Under Upper Arm

Questions? Contact Customer Service @ 800-297-9905
Or

Parts Diagrams see "Parts and Diagrams" section on web at www.rollrite.com

Rear Arm As Shipped

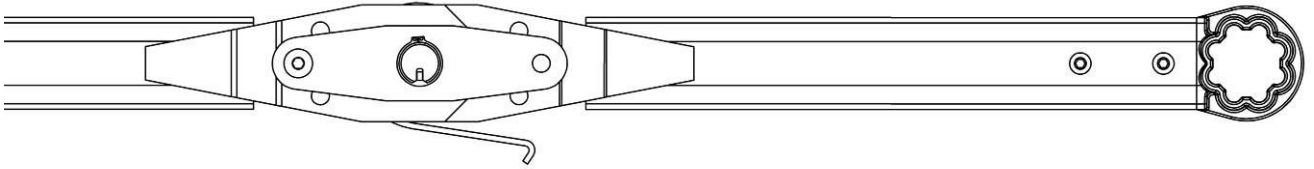
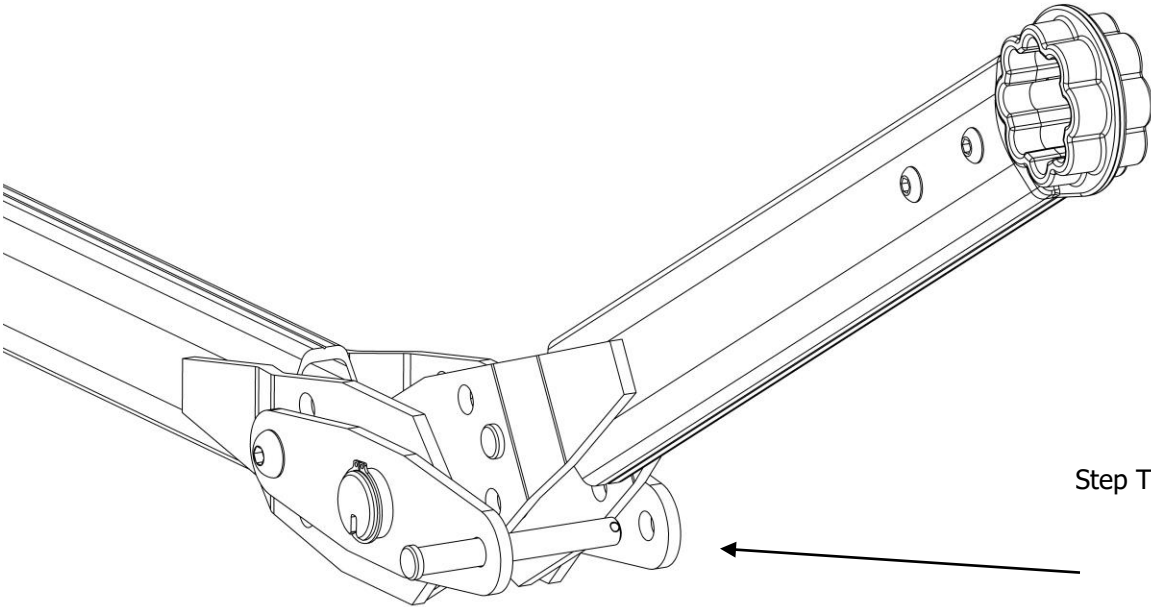
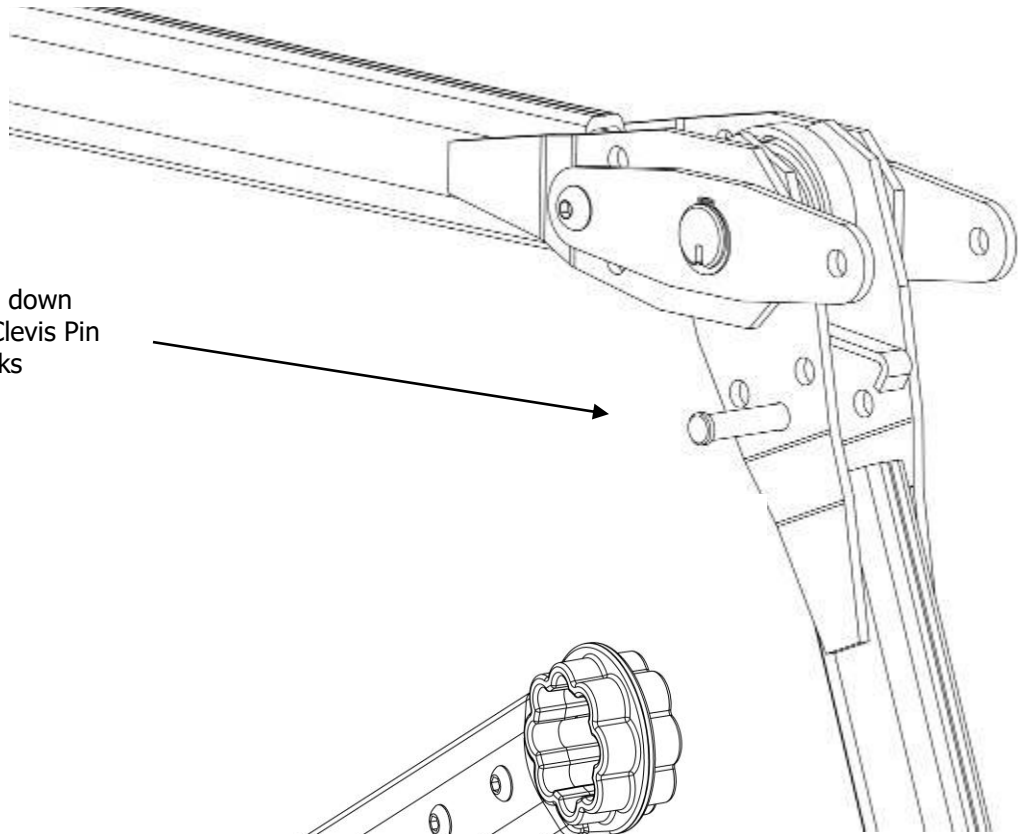

Figure 9
Passenger
Side
Stowing

Step One:
Rotate Upper Arm down
and Insert Short Clevis Pin
Under Spring Hooks



Step Two:
Rotate Upper Arm up
and Insert Long Clevis Pin
Under Upper Arm

3. Rotate the upper arm against the spring pressure until you can get the long clevis pin thru the holes under the upper pivot tube. Refer to step 2 in figure 8 or 9.
4. Attach the lower arm to the pivot pin and secure with set screws or the supplied snap ring depending on pivot type.
5. Remove the polymer bushing from the rear arm. Before installing the rear polymer bushing onto the axle slide one of the Axle collars 104812 onto the axle ahead of the Polymer Bushing. The second Axle collar will be positioned behind the polymer bushing. These components may have to be tapped with a rubber mallet to get them past the weld of the spline. Rotate the Rear arm up to the axle then reinstall the Polymer Bushing to the rear arm using the 3/8" button head fasteners. This should allow the hand crank spline to protrude through the back arm allowing the use of the hand crank handle.
6. Position the rear collar near the axle end ahead of the spline stub ensuring the fasteners will clear the inserted stub. Attach the rear PVC Axle Collar to the axle using three supplied 103830 1/4" X 1-1/4" Pan Head screws equally spaced around the circumference of the PCV Collar. The Axle Collar located ahead of the Polymer Bushing should be fastened similarly to the axle but only **AFTER** observing Rear Arm "float / drift" on the axle during motion. This arm travel is expected while the system is running and proper collar placement is important to allow free travel of the rear arm. The forward Axle Collar should be secured to the axle 1/2" ahead of the maximum arm travel position observed during your test run. See picture below.

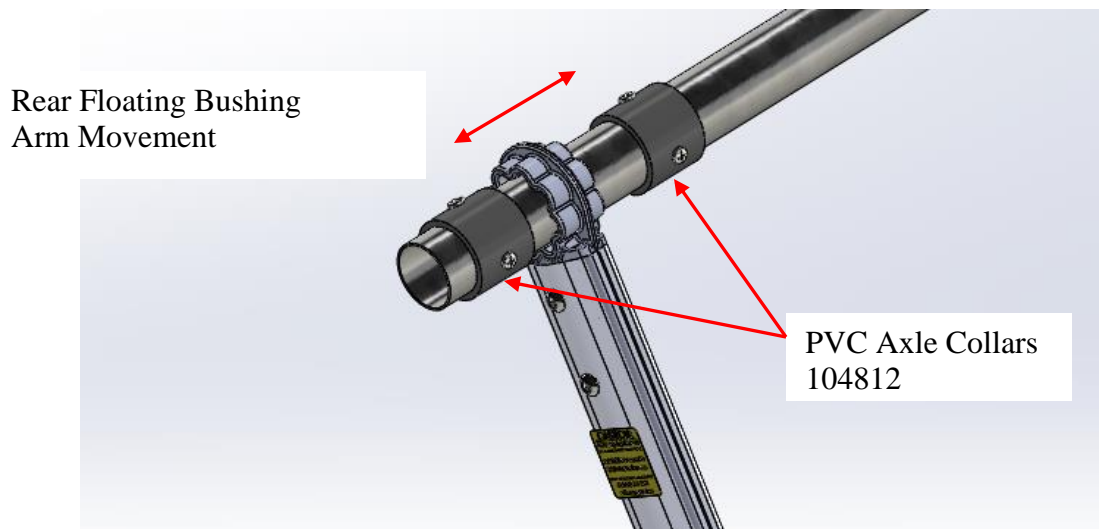

Questions? Contact Customer Service @ 800-297-9905
Or

Parts Diagrams see "Parts and Diagrams" section on web at www.rollrite.com

Flex Arm

1. Locate the rear Flex arm Components.
2. Assemble as shown below in figure 10.

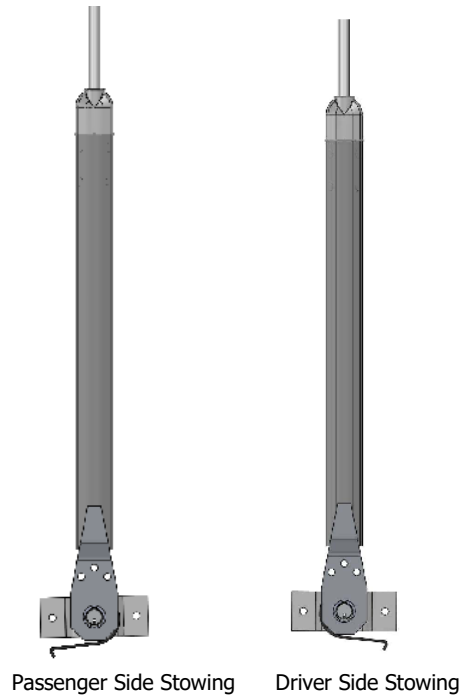

Fig.10

3. For standard Top Hinged Tailgate the pivot pin should be mounted between 28" and 36" down from the top of the trailer or arch if there is an arch on the trailer. It should be mounted 42" to Centered in from the lock down side of the trailer as well.

On a single piece Side-Hinged Tailgate, the pivot pin should be Centered left to right on the trailer and roughly 28" to 36" down from top of trailer.

This arm will compensate for some variation in mounting location. If you have a large rise in a high rise gate or a split swing door, mount the arm closer to the stowed side of the trailer rather than the lock down side.

4. Extend you tarp axle so that it is flush with the back of the trailer, or tailgate.
5. Insert the provided clevis pin through the holes in the arm under the tails of the springs. Typically this goes in the bottom hole, but it can be adjusted to give less spring tension.
6. At the rear of the trailer, lift the Multi-flex cable and align the axle adapter extrusion with matching inner surface of the axle (see Figures

Questions? Contact Customer Service @ 800-297-9905

Or

Parts Diagrams see "Parts and Diagrams" section on web at www.rollrite.com

below). Insert the axle adapter until it is flush with the end of the axle. Secure the axle in position at RIB with an 18140 1/4" x 3/4" self-drilling pan head Philips screw 1/2" from the end of the axle (see Figure below). Secure the axle cap to the mating holes in the axle using two 18100 1/4" x 3/4" hex head self-tapping screws being careful not to strip them out.

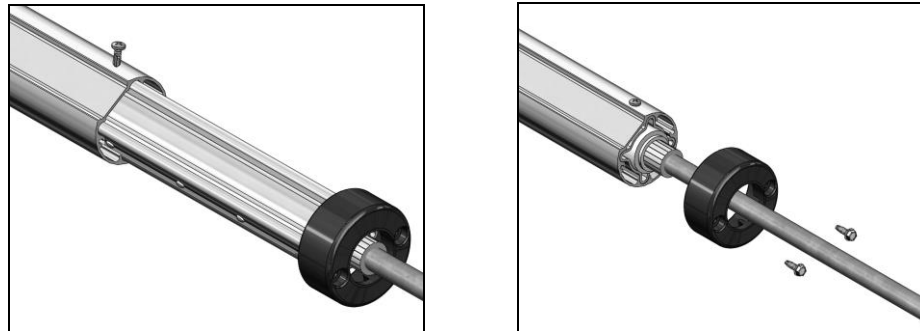

7. Run the Motor back and forth a few revolutions to insure the axle spins freely on the cable and the cable does not rub on anything.

Tarp Assembly

1. Layout the three axle pieces, as shown below in figure 11. (Try to get the motor adapter end of the axle pointing toward the front of the trailer.)
2. For single arm kits slide the three pieces together. If you have a dual rigid arm kit there will be 3 axle sections and an axle adapter that goes in the rear (found in the arm kit.) Make sure that the clip groove in the axle lines up in all sections. Refer to figure 11.

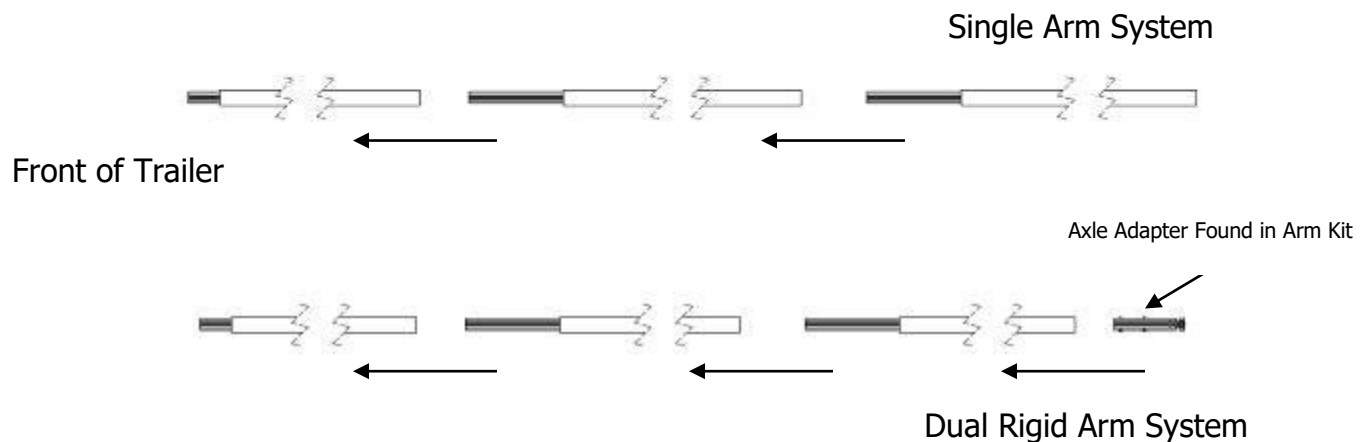

Figure 11

3. To secure the axle pieces together, drill thru one axle piece into the splice of another (about 10" in from the end of the empty section). We recommend using heavy-duty rivets because they have a smooth head

Questions? Contact Customer Service @ 800-297-9905

Or

Parts Diagrams see "Parts and Diagrams" section on web at www.rollrite.com

and will not wear on the tarp. You can also use flat head screws. With Dual arm Kits the rear adapter should be slid in so that the hole is out and 6" of it is visible and attach with provided screws through the axle into the ribs on the adapter.

4. Un-fold the tarp.

Tarp with Ridge Pole:

If your system has a ridgepole, there is a pocket in the center of the tarp, one end is open and the other is sealed shut. The end that is sealed shut needs to be at the front of the trailer and the pocket needs to be facing down.

Tarp without Ridge Pole:

If your tarp system does not have a ridgepole, the edge that has the double bindings needs to be pointing towards the front of the trailer.

5. Starting at the back of the tarp, slide the axle into the tarp until the front of the tarp is about 18" from the front of the axle. (This will require at least 2 people, one to slide the tarp onto the axle and the other to help feed the tarp.) **Do not attach the tarp to the axle at this time.**
6. Measure the distance between the end caps on the trailer and note the dimension
7. The ridgepole will slide together similar to the axle. Slide a splice half way into one section of ridgepole and then slide another piece onto that. Once it is together, crimp the grooves into the splices to prevent separation. You can crimp the splice in place by pinching the lip around it with pliers or by hitting it with a hammer. Refer to figure 12 for clarification.

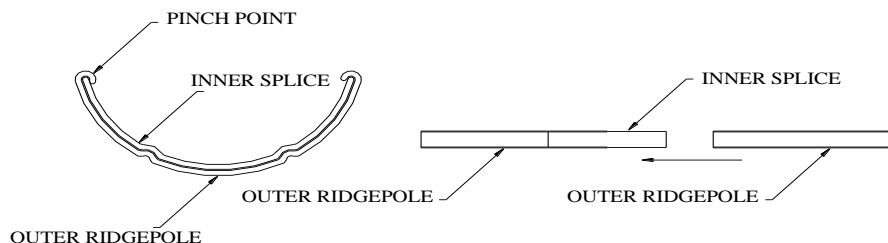

Figure 12

Questions? Contact Customer Service @ 800-297-9905

Or

Parts Diagrams see "Parts and Diagrams" section on web at www.rollrite.com

8. Using a grinder or a plasma cutter, cut the ridge pole 7" less than the distance between end caps (noted in step 6). Round off the top points at both ends of the ridgepole to prevent it from jabbing through the tarp during lockdown. Use a generous radius (start 3 – 4" back) and ensure there are no sharp edges.
9. Slide the ridgepole into the pocket of the tarp upright. (The cup needs to face up). Refer to figure 13.
10. Assemble the tarp rod (1-1/8" aluminum tube or 1-1/8" steel tube) similar to the axle and ridgepole and rivet, crimp or screw the sections together.
11. Measure the tarp and cut the tarp rod off a minimum of 1" longer than the tarp.
12. Slide the tarp rod into the pocket on the "passenger's side" of the tarp. There will be approximately 1/2" of the rod sticking out from each end of the tarp. If Driver Stowing it will appear opposite. Refer to figure 13 for proper tarp assembly.

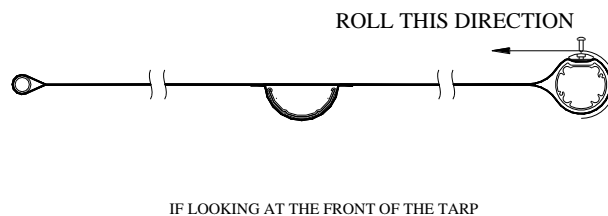

Figure 13

13. Roll the tarp up starting with the axle. (As shown above in Figure 13)
14. Set the tarp on the passenger side of the trailer with the tarp rod setting in the tarp tube locks. **Note:** The tarp should be coming off the bottom of the axle.
15. Center the tarp over the opening to be covered.
16. Lock the tarp rod into the tarp tube locks by replacing the top bolt. Do this to the front and rear hook and a few in between. This will allow easier adjustment if needed.

Questions? Contact Customer Service @ 800-297-9905
Or
Parts Diagrams see "Parts and Diagrams" section on web at www.rollrite.com

17. Roll the tarp to the driver side of the trailer.
18. Slide the polymer bushing that was taped to the arm onto the motor adapter that is welded into the front of the axle. Refer to figure 14.

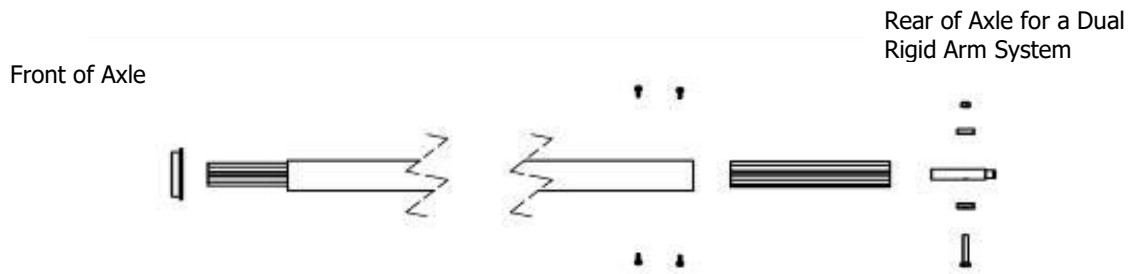

Figure 14

19. Rotate the knuckle arm up to the axle and slide the axle onto the motor shaft. Bolt the axle to the motor using the 3/8 bolt and shims supplied. Make sure that the polymer bushing is seated in the casting on the front arm. Refer to figure 15.

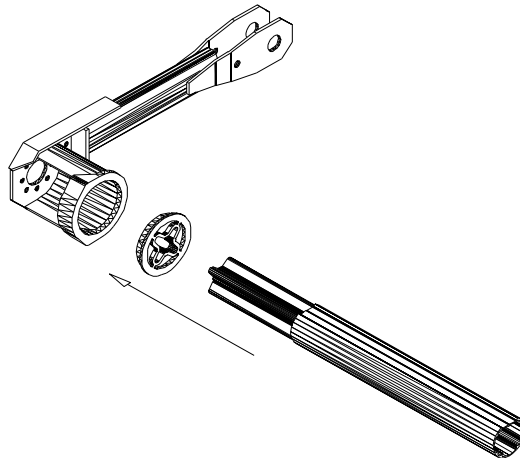

Figure 15

20. Lock the rest of the hooks.
21. Locate the tarp clips (rectangular plastic pieces with two counter bored holes).
22. With the 3" Axle Tarp Clip groove mounting surfacing facing straight down attach a tarp clip 37831 centered over the FRONT binder. Securely fasten the clip to the axle using two 18140 self-drilling pan head screws provided. Attach another clip immediately behind the first clip. See figure below for positioning. The outside Clip will overhang the FRONT of tarp by 1"

Questions? Contact Customer Service @ 800-297-9905

Or

Parts Diagrams see "Parts and Diagrams" section on web at www.rollrite.com

Tarp Clip positioning at FRONT Tarp Reinforcement



23. For a 53'2" long tarp space another nine individual clips out every 58.8" edge to edge starting from front side and secure with the supplied 18140 self-drilling pan head screws. Be sure to push any slack in the tarp toward the back of the trailer as you go.

For Rigid Dual Arms systems ALL of the tarp clips can be fastened to the 3" axle using the 1/4" x 3/4" self-drilling pan head Philips screws.

For systems using a Rear Flex Arm return the REAR pair of Tarp Clips require a different fastener. Instead of using self-drilling screws here it is recommended to use SELF-TAPPING 1/4 x 3/4" screws and pilot holes. This is to ensure a secure connection as the fastener has to penetrate two layers of Aluminum in this rear section.

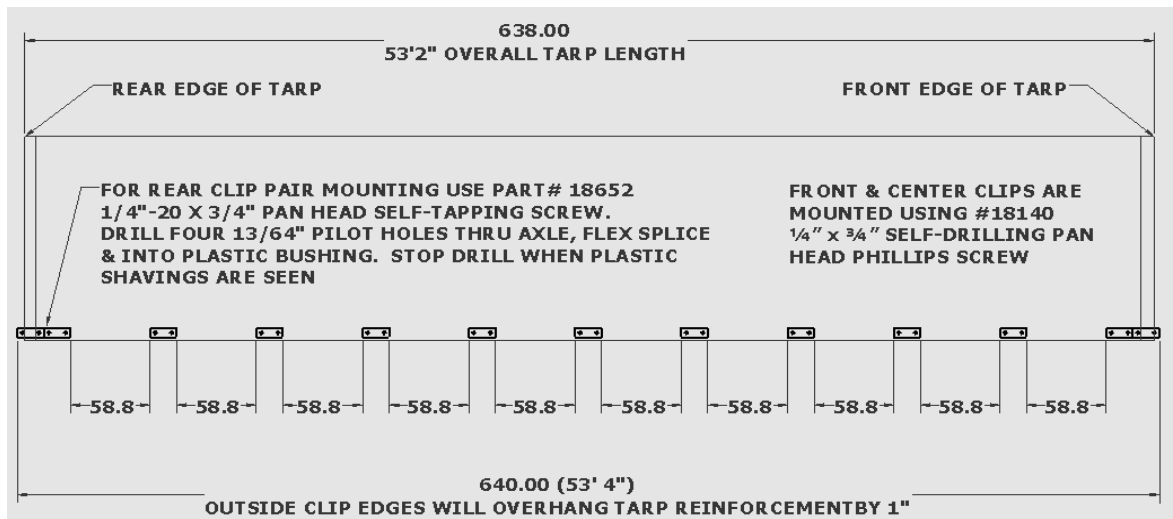

Using 13 total clips, a tarp 50' 2" long will require an edge to edge tarp clip spacing of 55.2"

Using 13 total clips, a tarp 48'2" long will require an edge to edge tarp clip spacing of 52.8"

Questions? Contact Customer Service @ 800-297-9905

Or

Parts Diagrams see "Parts and Diagrams" section on web at www.rollrite.com

24. As noted in diagram above, attach the last pair of axle clips to the tarp rear binder in the same manner as the front binder but use four 18652 1/4"-20 x 3/4" Pan Head Self Tapping screws.
- Position a tarp clip 37831 centered over the rear binder and drill two 13/64" pilot holes using the existing clip holes as a guide. Drill thru exterior aluminum axle, interior aluminum flex spline & thru the interior plastic bushing. STOP drill when you see plastic shavings.
Do not drill into the interior flex Cable
 - Securely fasten the clip to the axle using the Self-tapping 18652 1/4"-20 x 3/4" Pan Head screws being cautious not to strip the threads. The outside clip will overhang the binder by 1".
 - Position another clip immediately in front of the first clip and drill another set of 13/64" pilot holes.
 - Securely fasten the clip to the axle using the Self-tapping 18652 1/4"-20 x 3/4" Pan Head screws being cautious not to strip the threads. See figure below.



25. If the axle is too long it can be cut down at this point. With dual rigid arm systems you will have to measure how much is sticking past the rear arm, cut the axle off and re-install the adapter and stub shaft to connect to the rear arm. (Figure 14)

Wiring the System

Refer to the wiring diagram included with the wiring kit.

Questions? Contact Customer Service @ 800-297-9905
Or
Parts Diagrams see "Parts and Diagrams" section on web at www.rollrite.com

Pivot Installation Section

To compensate for varying types and styles of trailers, we offer 5 styles of pivot mounts. View the illustrations below to determine which mount you have and follow the installation instructions that correspond to that type of pivot (roller bearing catwalk mount not pictured).

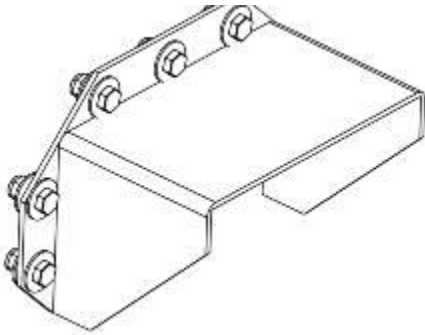

Standard Pivot Mount

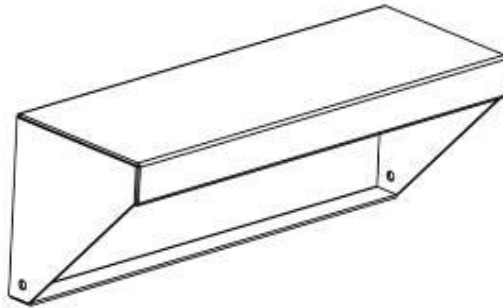

Grain Trailer Mount

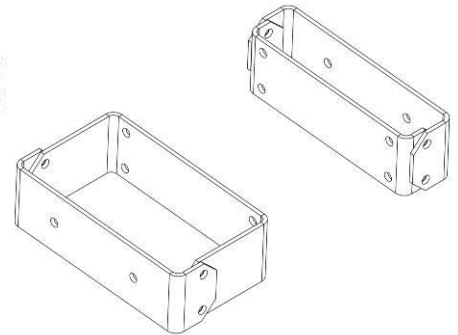

Multi-Flex Mount

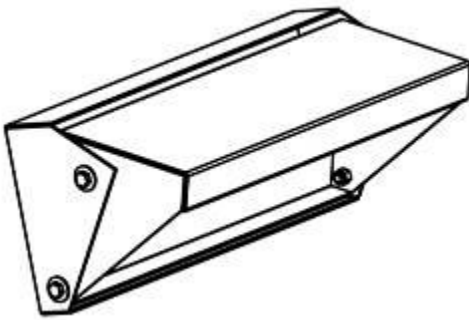

Adjustable Mount for
Grain Trailer

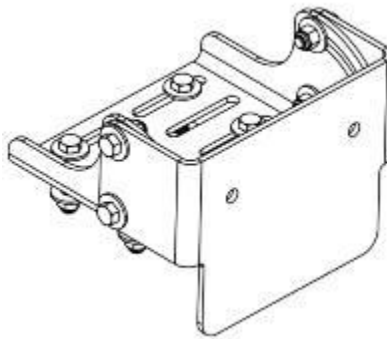

Cat Walk Ext. Pivot Mount

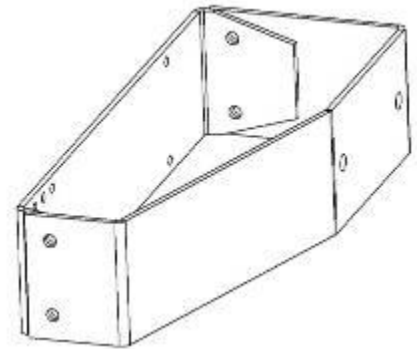

Universal Ext. Pivot Mount

Standard Pivot Mount Installation

1. Measure down from the top of the trailer 20" and put a horizontal mark on the face of the trailer, near the center. For High lift Rendering applications use the following criteria. Trailer width of 102" measure down 20". Trailer width of 96" measure down 25".

Note: If the nose of the trailer is taller than the side rails, add the height of the rise to the 20" and put a horizontal mark. (Refer to figure 16 below.) Example: If the rise on the nose is 10", measure down from the top of the nose 30" and put a mark.

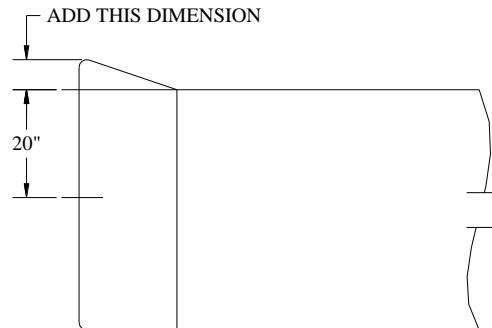

Figure 16

2. On a passenger stowing system both the front and the rear pivot mounts will need to be offset from the center of the trailer by 1 1/2", towards the driver's side. Refer to figure 17 below for clarification. On a driver stowing system, they will need to be offset 1 1/2" toward the passenger side of the trailer.

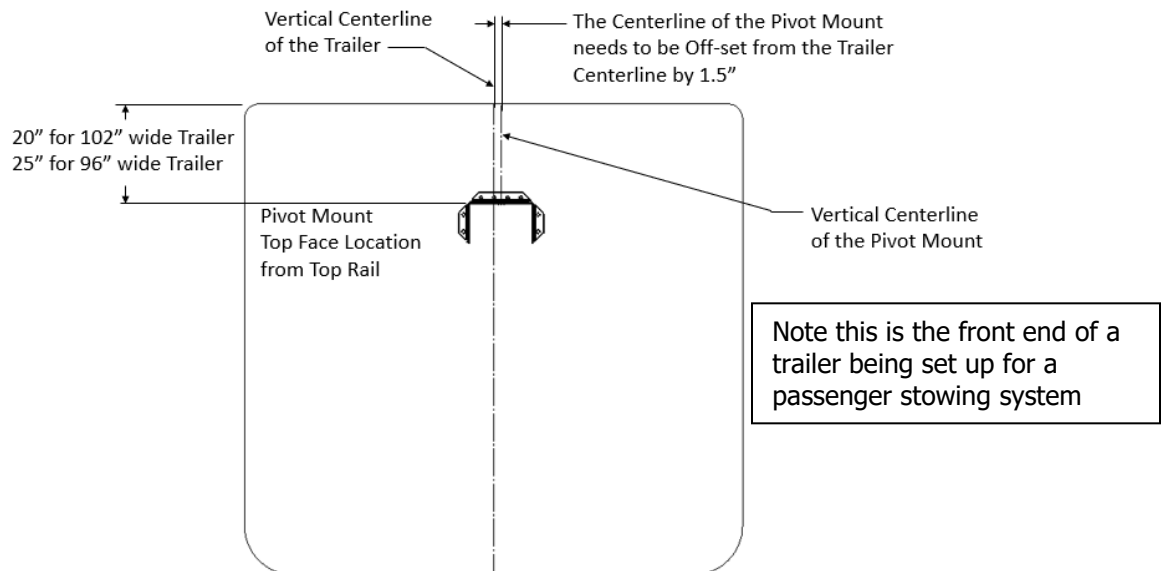

Figure 17

3. Center the mounts on the offset vertical line at the same height as the horizontal mark made in step 2.

Questions? Contact Customer Service @ 800-297-9905

Or

Parts Diagrams see "Parts and Diagrams" section on web at www.rollrite.com

Note: The flat portion of the mounting bracket, not the bolt flange, needs to line up with the horizontal mark.

4. Bolt the mounts in place using the 1/2 x 1-1/2" bolts supplied.
5. Center the Top Mount pivot boxes on the pivot mounts and bolt them in place, using the 1/2 x 1-1/2" bolts supplied. The pivot pins should now be centered on the face of the trailer. Refer to figure 18.

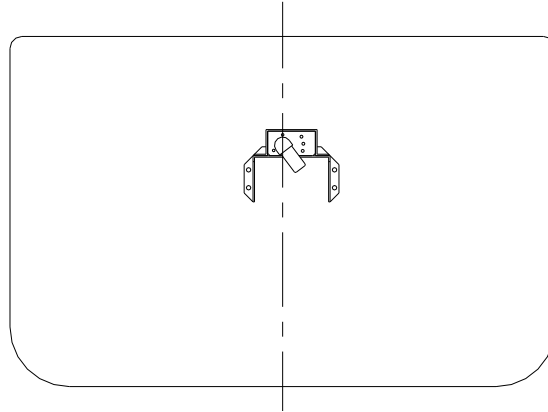

Figure 18

Continue with step 1 under **Front Arm Assembly**.

Grain Trailer Mount Installation

1. Measure down from the top of the trailer 20" and put a horizontal mark on the front and rear face of the trailer, near the center.
2. Center the brackets on the face of the trailer as best a possible, making sure that top of the mounts line up with the mark made in step 1. (20" down from the top of the trailer.)
3. Make sure that the mounts are level with the trailer and fasten the mounts to the faces of the trailer. Make sure that you hit at least **3** reinforcing ribs behind the sheet metal on each mount if you are bolting the mounts in place. If the ladder interferes and you are only able to hit 2, fasten it to the ladder as well.
4. Place the pivot boxes on top of the mount with the pivot pin facing out.

Questions? Contact Customer Service @ 800-297-9905

Or

Parts Diagrams see "Parts and Diagrams" section on web at www.rollrite.com

5. Position the pivot boxes so that the pivot pins are centered on the trailer. Refer to figure 19.

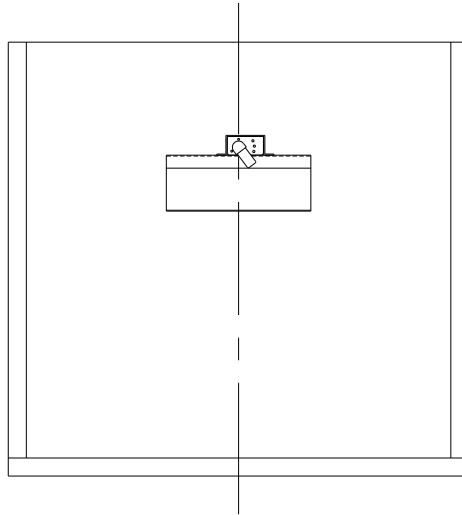

Figure 19

6. Make sure that the pivot boxes are flush with the front edge of the mount.
7. Mark the location of the holes in the pivot boxes on the mounts by using the holes in the box as a template.
8. Drill (4) 11/16" inch holes at the marks made in the previous step.
9. Bolt the pivot boxes to the mounts, using the (4) 1/2 X 1-1/2 bolts supplied.

Continue with Step 1 under **Arm Assembly.**

Questions? Contact Customer Service @ 800-297-9905

Or

Parts Diagrams see "Parts and Diagrams" section on web at www.rollrite.com

Adjustable Grain Trailer Mount

1. From the top of the trailer, measure straight down 20" and put a mark on the front and rear face of the trailer. Refer to the figure 20 below.

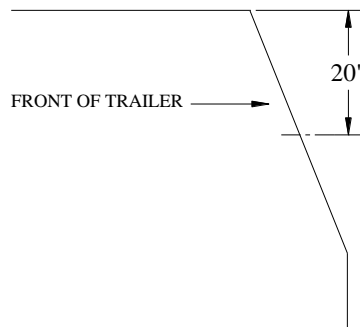

Figure 20

2. Line the top edge of the mounts up with the horizontal lines made in step 1 and center the mount on the face of the trailer.

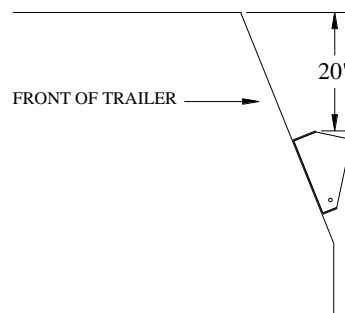

Figure 21

3. Make sure that the mounts are level with the trailer and fasten the mounts to the trailer. Make sure that you hit at least **3** reinforcing ribs behind the sheet metal on each bracket if you are bolting the mount in place. If the ladder interferes and you are only able to hit 2, fasten it to the ladder as well.
4. Place the pivot mounts inside the adjustable brackets and place a 1/2 x 1-1/2" bolt thru each side. Snug the bolts enough to keep it from rotating freely, but do not completely tighten.
5. Make sure that the mounts are now level with the top of the trailer. If not, adjust accordingly.
6. Tighten the bolts in the bottom of the mounts.

Questions? Contact Customer Service @ 800-297-9905

Or

Parts Diagrams see "Parts and Diagrams" section on web at www.rollrite.com

7. Drill a 1/2" hole thru the adjustable mounts and the pivot mount on both sides of each bracket.
8. Bolt the 2 pieces together, using 2 of the 1/2 X 1-1/2" bolts supplied.
9. Bolt the pivot boxes to the mounting brackets, using the (4) 1/2 X 1-1/2" bolts supplied.

Continue with Step 1 under **Arm Assembly.**

Catwalk Mount Roller Bearing Pivot

1. Attach the pivot and pivot mounting plates to the catwalks using the supplied 5/8" bolts. The pivot pins should be centered horizontally on the trailer (see Figure 12 on page 11). Verify that the pivot boxes are square to the faces of the trailer before tightening the fasteners.
2. Measure from the center of rotation of the pivot pin to the driver side top corner of the trailer. Measure to the passenger side top corner to verify the pin is centered. Write down the measurement.
3. Lay the pivot arms out on the floor with the knuckle straightened. Add 12" to the measurement in step 2 and cut the arm assembly to this length (cutting off from the base of the arm).
4. Drill and tap two 1/2" -13 holes centered at 1" and 3" from the base.

Continue with step 1 under **Arm Assembly.**

Figure 22

Catwalk Mount External Style Pivot

1. Locate the base mounting plate (see Figure 22)

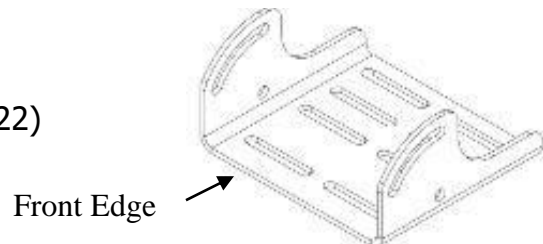

2. Position it on the cat walk so that it is centered on the trailer and the front Edge (refer to Figure 22) is flush with the outside of the ladder or slightly beyond, this will insure that the arm does not rub on the ladder during operation.
3. Bolt bracket in place.
4. Locate Pivot mount face plate and bolt it to the base mounting plate as shown in Figure 23. Note the slotted holes in the base mounting plate these will allow you to level the face mounting plate if your catwalk is not level with the ground. The face plate must sit vertically so if you have a slope nose trailer and your catwalk is perpendicular to the trailer you will have to level this bracket using the provided slots.

Questions? Contact Customer Service @ 800-297-9905

Or

Parts Diagrams see "Parts and Diagrams" section on web at www.rollrite.com

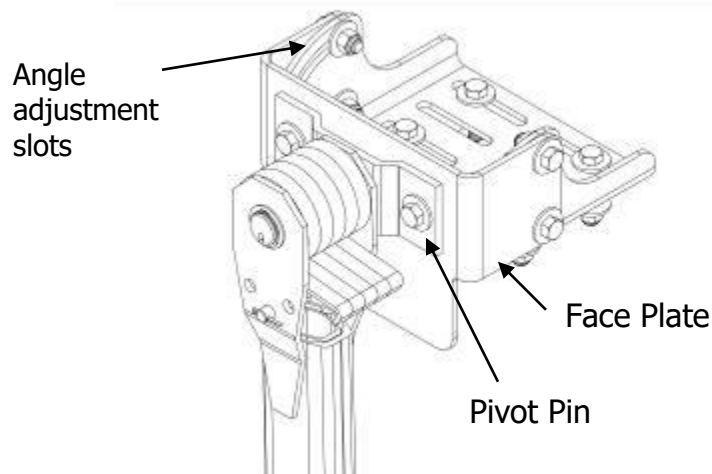

Figure 23

5. Bolt Pivot the pivot pin to the face plate as shown in figure 23, not the pin will be installed in the arm as shown in figure 23. Figure 23 shows a front arm for a pass stowing power kit.
6. Repeat above steps with the rear arm mounts.
7. Arm length can be adjusted after the system is operational. Typical adjustment is to set the base arm's overall length equal to the distance from the top of the arch to the catwalk. This way the arm will not stick up above the trailer when the tarp is in the stowed position. To adjust arm length simply loosen the set screws in the outer base pivot tube and slide the inner arm in or out as needed. The inner arm can be cut down if it is too long.

Continue with step 1 under **Arm Assembly**.

Universal External Pivot Mount

1. Used on Grain Trailers with rigid front and rear arms. On FRONT & REAR of the trailer measure from the top of the trailer, straight down approximately 23 1/2" and put a mark on the front and rear face of the trailer (If this interferes with the catwalk the arm can be mounted higher.) This line should be as close to center as possible. Refer to the figure 24 below.

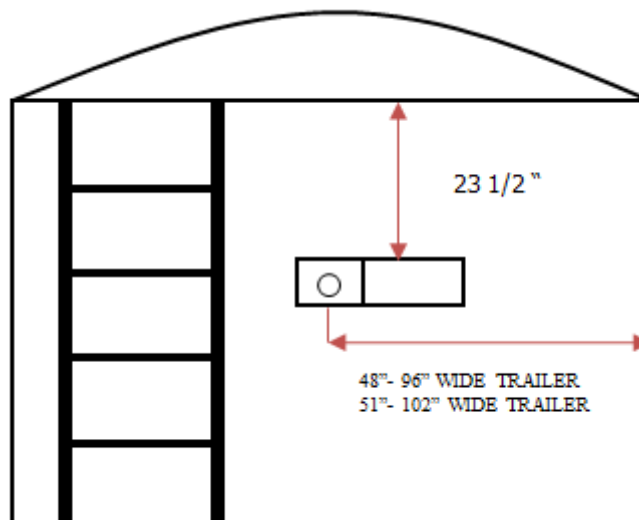

Figure 24

Questions? Contact Customer Service @ 800-297-9905

Or

Parts Diagrams see "Parts and Diagrams" section on web at www.rollrite.com

2. Line up the top of the inner bracket with the mark made in the previous step. Remove existing rivets that will be behind bracket (6 total). Align the holes in the inner bracket with holes on nose of trailer and bolt in place, using (4) 3/8" button head bolts, (4) 3/8" ID Nylon Washer between trailer wall and bracket, (4) 3/8" washer and (4) 3/8" nylok nuts provided. **Make sure that the 15/16" hole is towards the roadside of the trailer on both front and rear.**
3. On the rear of the trailer remove four rivets (leave middle rivets in place) bolt in place using (4) 3/8" bolt, (4) 3/8" ID Nylon Washer between trailer wall and bracket, (4) 3/8" washer, and (4) 3/8" nylock nuts provided.
4. If you have a square nose trailer bolt the outer brackets to the inner bracket using (4) 1/2" Hex Head bolt , (8) 1/2" Flat washer & (4) 1/2"-13 Nylock nuts. Align the outer bracket so that the top is parallel with top of trailer. Tighten bolts when top of outer bracket is parallel to top of trailer. It will appear as shown in figure 25 below.

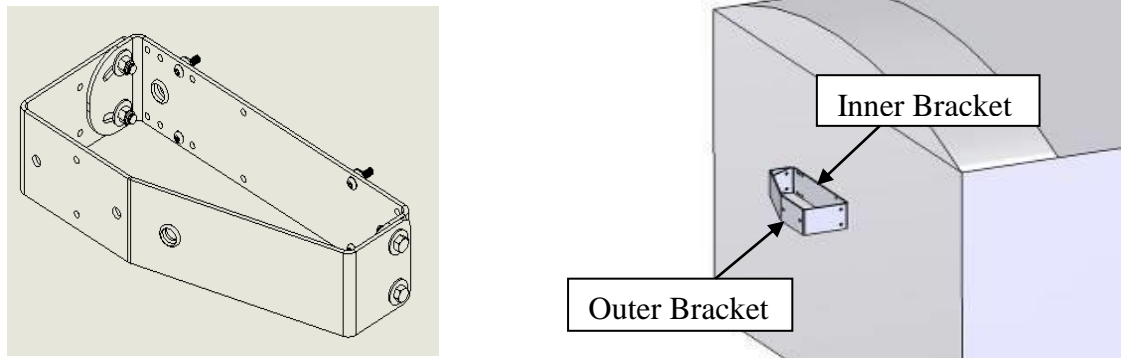
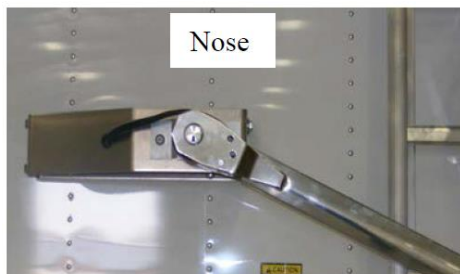

Figure 25



Note: The angle of the bracket is opposite the ladder side on both the nose and rear of the trailer.

5. If you have a slope nose trailer bolt the outer brackets on using (4) 1/2"

Questions? Contact Customer Service @ 800-297-9905

Or

Parts Diagrams see "Parts and Diagrams" section on web at www.rollrite.com

Hex Head bolt , (8) 1/2" Flat washer, & (4) 1/2"-13 Nylock nut.
Rotate the brackets down until the top of the outer bracket is parallel to the top of the trailer as noted in figure 26 below. Tighten bolts when top of outer bracket is parallel to top of trailer.

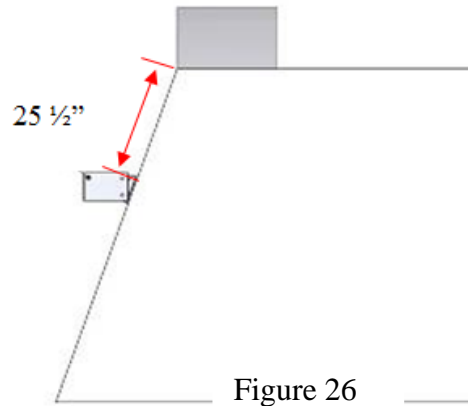

6. Mount the pivot pins that are in the arms to the Outer bracket through the provided holes in the face of the outer bracket as shown in figure 27 below. Note the groove in the pin should point down

The fasteners for each pivot pin are baged separately in the arm kits and will include the following Fasteners:

1. 18295 Bolt 1/2" X 1 1/2" Button Head (x2)
2. 18412 Washer 1/2" Flat Washer (x2)
3. 18631 Nut 1/2"-13 Nylock (x2)

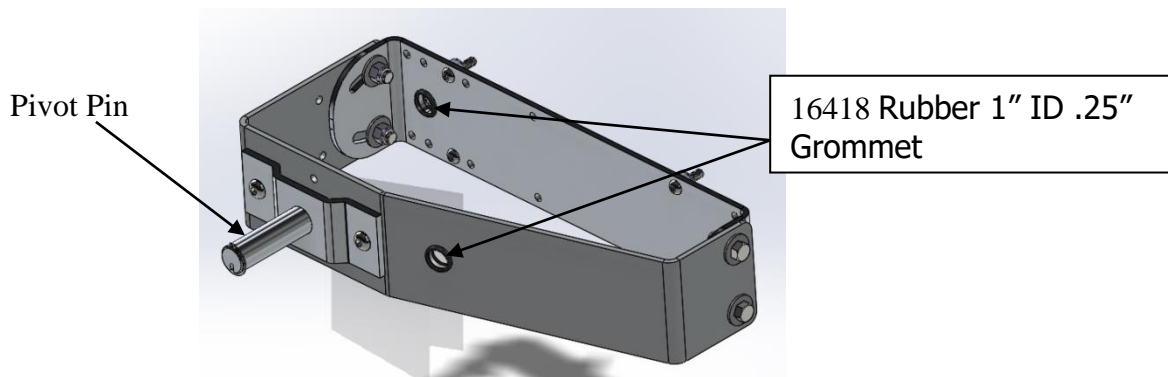

Figure 27

7. Drill 7/8" hole in the nose of trailer using hole in bracket as a guide. This will be used for wire to pass through. Install a 16419 Rubber 7/8" ID x .125" groove grommet into this hole.

- At the trailer nose side, insert a 16418 Rubber 1" ID .25" groove grommet into both the outer and inner 15/16" bracket holes. Shown in figure 27.

Continue with step 1 under **Arm Assembly**.

Multi-Flex Pivot Mount

- On the front of the trailer measure from the top of the trailer, straight down approximately 25" and put a mark on the front face of the trailer (If this interferes with the catwalk the arm can be mounted higher.) This line should be as close to center as possible. Refer to the figure 28.

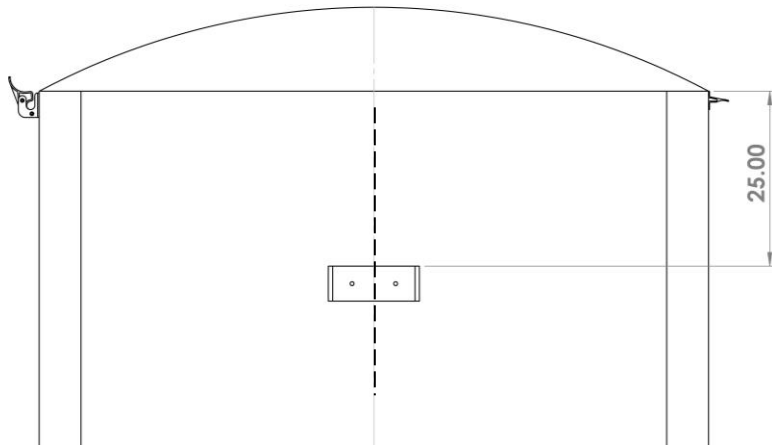
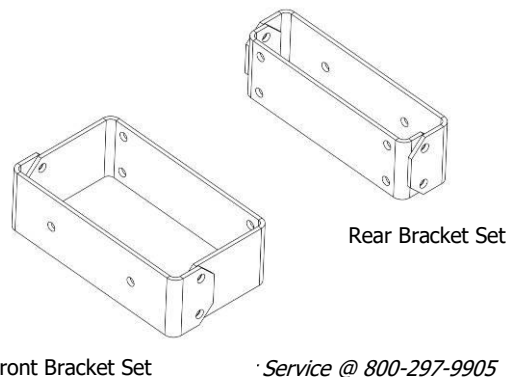

Fig 28

- Align the top of the inner mounting bracket with line made in step one and centered on the trailer and mark the mounting holes.
- Drill 1/2" clearance holes where you marked in step 2.
- Bolt the inner bracket in place. Note the front mount has longer legs on it (see Fig 29)
- Bolt the outer bracket onto the inner bracket. **IMPORTANT-** Loose fit the outer bracket to the inner bracket using #18296 1/2" x 1 1/2" hex head bolts, nuts, and flat washers. Do not completely tighten yet. Align the outer bracket so that the top is parallel with top of trailer. Alternatively, the arm should be parallel to the vertical front wall before the fasteners are tightened.

Figure 29



Service @ 800-297-9905

- 6) Bolt the Pivot Pin (installed in arms) to the mounting bracket. Note the slot in the pin should point down – see Fig. 30. Then Continue with Step 1 under Arm Assembly.

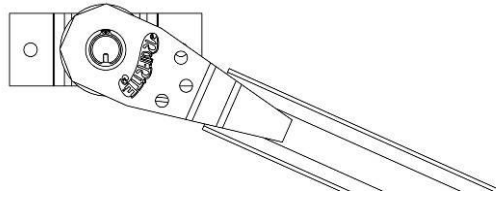

Fig 30

- 7) The Tailgate style affects the position of the Rear Multi-Flex Rear Bracket Set Pivot Mount. For standard Top Hinged Tailgate the pivot pin should be mounted between 28" and 36" down from the top of the trailer or arch if there is an arch on the trailer. It should be mounted 42" to Centered in from the lock down side of the trailer as well.

As an Example, to accomplish this, measure down and make a horizontal mark 29½" from the top of the tailgate. Measure in and make a vertical mark 36¾" from the trailer side wall on the lock down side of the trailer. See Figure 31 below for measurements on a driver stow/passenger side lockdown system. The left picture is measurements for the bracket location, the right picture shows where the pin will end up being positioned.

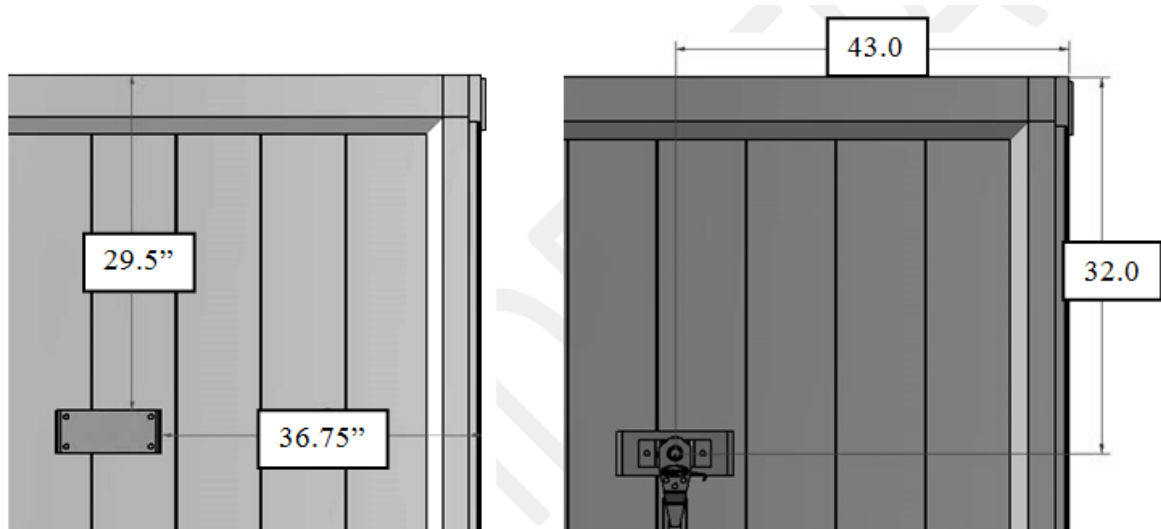

Figure 31

On a single piece Side-Hinged Tailgate, the pivot pin should be centered left to right on the trailer and roughly 28" to 36" down from top of trailer.

This Rear Flex arm will compensate for some variation in mounting location. If you have a large rise in a high rise gate or a split swing door, mount the

Questions? Contact Customer Service @ 800-297-9905

Or

Parts Diagrams see "Parts and Diagrams" section on web at www.rollrite.com

arm closer to the stowed side of the trailer rather than the lock down side.

- 8) Again it is IMPORTANT to loose fit the outer bracket to the inner bracket using #18296 1/2" x 1 1/2" hex head bolts, nuts, and flat washers. Do not completely tighten yet.
- 9) Secure the Multi-Flex rear arm assembly to the bracket using the two 1/2" button head bolts. The head must be installed on the outside surface without a washer. Only use washers on the inside surface under the nut.
- 10) IMPORTANT - Make sure the arm is parallel with the tailgate and tighten the fasteners on the Outer mount from step 8.

With the arm hanging straight down, install the 1/2" x 4 1/8" clevis pin in the hole closest to the spring's tabs. This is the maximum setting for spring tension. Secure the clevis pin using a cotter pin. See Figure 32 below for proper installation on a Rear Flex Arm Driver Stowing system.



Figure 32

Questions? Contact Customer Service @ 800-297-9905

Or

Parts Diagrams see "Parts and Diagrams" section on web at www.rollrite.com

Operating Manual

- To cover the load, actuate the switch to the close/cover position. The springs in the arm will move the tarp from the stowed position and across the trailer to the tarped position. Release the switch when the tarp and axle is locked under the locking lip and stops moving. *Do not hold the switch once the close cycle is complete. Doing so could cause damage to the motor as well as the tarp.*
- To uncover the load, actuate the switch to the open/uncover position. The Gear motor will wrap the tarp around the tarp axle causing the axle to move from the tarped position to the stowed position. Release the switch/lever when the axle is resting in the tarp catches. *Do not hold the switch once the open cycle is complete. Doing so could cause damage to the motor as well as the tarp.* This tarp system can be opened part way and stopped. Anytime you release the switch the tarp system will stop. It will not hurt the tarp system to stop part way through the tarping cycle. *Never travel with the tarp in a partially covered position. The trailer should be covered as often as possible when traveling.*

Optional arm adjustment:

Different types of loads and conditions may require your tarp to operate differently. That is why Roll Rite has designed your tarp system to be very versatile. Please see the steps below to adjust your arm if need be.

-To make arm carry higher over heaped loads:

Increase the knuckle pressure or reduce the pressure in the base pivot box. Adjusting both will over even more noticeable results.

- To make the arm follow the profile of the end caps:

Decrease the knuckle pressure or increase the pressure in the base pivot box. Adjusting both will offer even more noticeable results.

Questions? Contact Customer Service @ 800-297-9905

Or

Parts Diagrams see "Parts and Diagrams" section on web at www.rollrite.com

Maintenance Manual

Roll Rite, LLC designs its tarping systems and power kits to be as maintenance free as possible, contributing to the overall value of the product.

Maintenance intervals vary based on environmental conditions.

Roll Rite, LLC recommends that:

- All electrical connections should be cleaned and greased regularly to prevent corrosion (fill all electrical boots, limit switch boots, etc. with dielectric grease). Electrical connections can be found at all motors, switches, contactors, limit switches, control boxes and batteries.
- All bearings with grease fittings and tower legs must be greased regularly.
- Check and tension all set screws. Set screws should be tightened until they touch and then torque them $\frac{3}{4}$ of a revolution beyond that.
- Check motor mounting bolts and torque to 70 in-lbs (5.8 ft-lbs).
- All mounting hardware should be checked to insure all system components are securely fastened.
- Visually inspect all moving parts for abnormal or excessive wear.

Questions? Contact Customer Service @ 800-297-9905

Or

Parts Diagrams see "Parts and Diagrams" section on web at www.rollrite.com

Once Again Roll Rite, LLC would like to Thank You for your business and offer you not only the finest product in our industry, but the best customer service as well. We would like to invite you to visit our web site at www.rollrite.com, where you can find a complete set of parts diagrams.

Additionally we would love to hear from you if you have any questions or issues:

Phone - 800-297-9905

Fax – 888 TARP FAX (888-827-7329)

E-mail – info@rollrite.com

Questions? Contact Customer Service @ 800-297-9905

Or

Parts Diagrams see "Parts and Diagrams" section on web at www.rollrite.com