

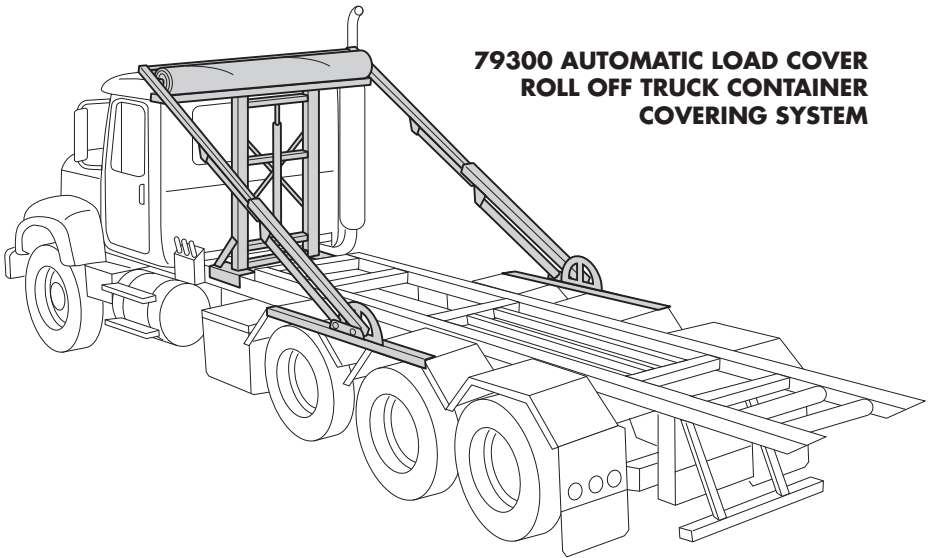

Automated Covering Systems

Roll-Rite LLC and its entire staff would like to thank you for your purchase of one of the finest tarping systems in the industry

INSTALLATION INSTRUCTIONS



79300 AUTOMATIC LOAD COVER ROLL OFF TRUCK CONTAINER COVERING SYSTEM

Customer Service:
800-297-9905 or 860-309-6523
email: tylerb@rollrite.com

CONTENTS

Overview	4
Gantry Installation	4
Pivot Mount Framework Installation	8
Pivot Installation	9
Hydraulic Routing and Installation	10
Lift Cylinder Installation	14
Torsion Tube and Tarp Installation	13
Arm and Extend/Retract Cylinder Installation	16
Preloading Torsion Tube Assembly	19
Arm Safety Stop Installation	20
Operation	22
Maintenance	23

TOOLS REQUIRED

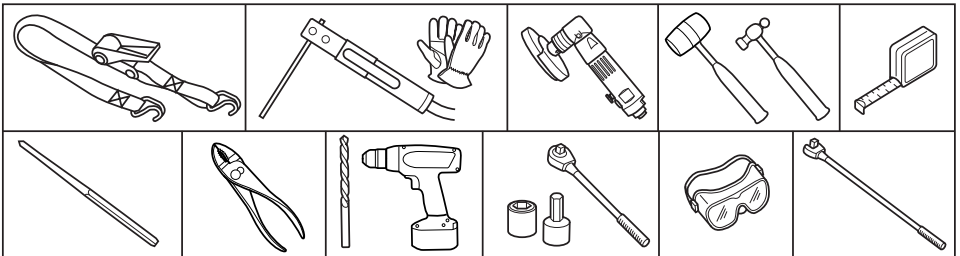

- Ratcheting Tie Straps
- Cutting Tools, Cutting Torch or Plasma Cutter
- Steel Welding Tools
- Grinder
- Tap Hammer or Heavy Rubber Mallet
- Heavy Awl
- Pliers
- Tape Measure
- Clamps
- Drill and Drill Bits – 33/64” and 5/8” - Bridge Reamer for hole clean up
- Breaker Bar
- Socket Wrench
- Sockets: 1/2” - 9/16” - 5/8” - 3/4” - 11/16” - 1 1/8” - 15mm - 3/16” Allen

SYSTEM COMPONENTS

- A) Gantry
- B) Tarp Spool Support Bar/Gantry Top
- C) Tarp Tracking Bar
- D) Pivot Mount
- E) Arm Guide Arch Bracket
- F) Flow Divider Mount Plate
- G) Flow Divider Valve
- H) Hydraulic Fittings and Adapters
- I) Torsion Tube and Tarp Assembly
- J) Lower Arm
- K) Upper Arm
- L) Lift Cylinders
- M) Arm Extension Cylinders
- N) Hydraulic Hoses
- O) Spool Valve
- P) Lower Arm Guide Block
- Q) Upper Arm Mount Plates
- R) Priority Flow Valve
- S) Stop Bracket

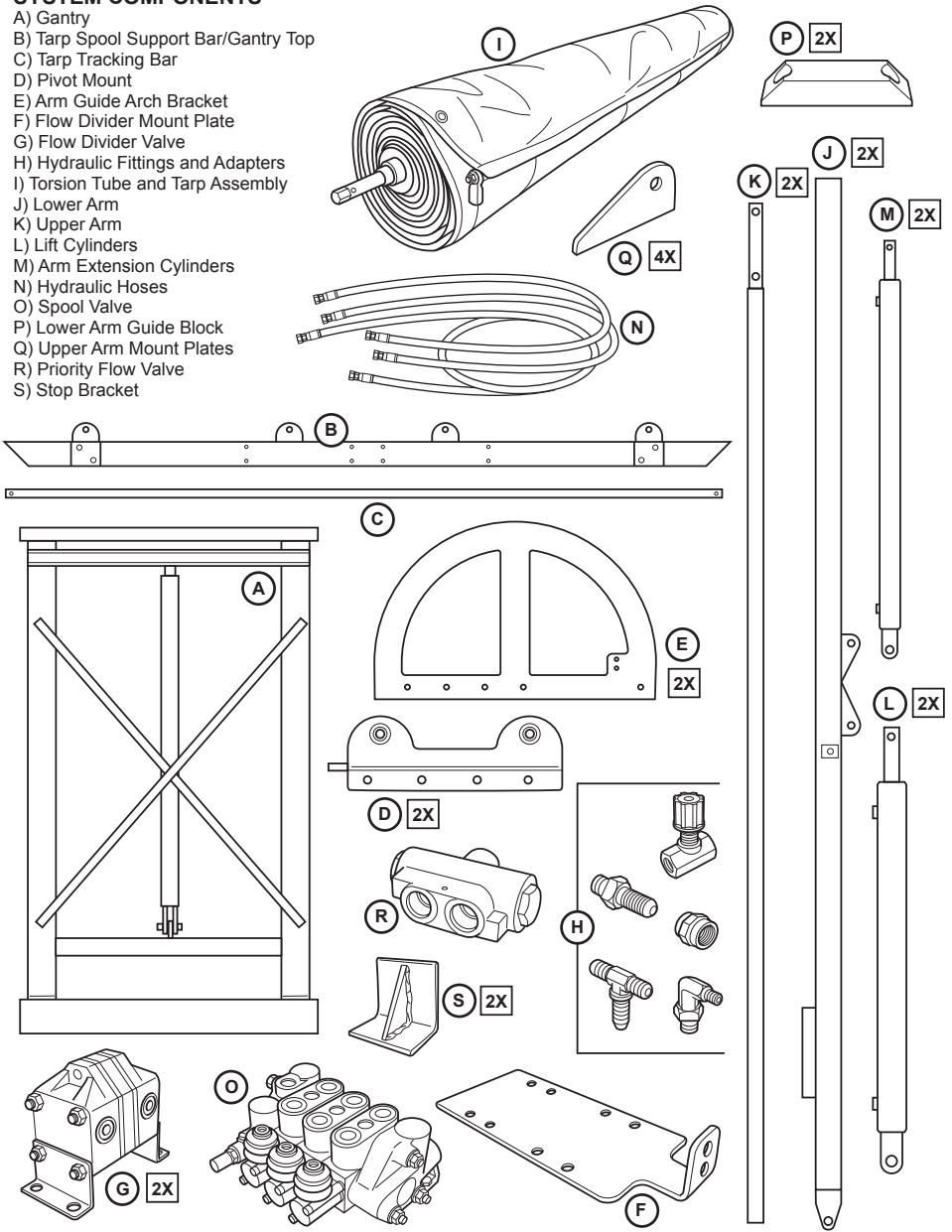

OVERVIEW

Begin by inspecting overall vehicle condition and locations of existing equipment, including hydraulic hoses, reservoir tanks and hydraulic controls.

NOTE: *The exact mounting and installation steps required can vary depending on the vehicle. The technician will need to determine the best locations and possible custom fabrications needed based on each installation.*

IMPORTANT:

The gantry must be located so that all surfaces have a minimum clearance of 2" from the truck cab and the roll-off frame surfaces not related to the attachment of the gantry.

The gantry must be located so that the rolled tarp assembly has a minimum clearance of 5" from any engine exhaust components.

Determine best mounting locations at frame behind cab. Be sure a flat, horizontal surface is open and free of obstructions for the base of the gantry.

1. GANTRY MOUNTING BRACKETS

- Measure the distance between the hoist sheave and rear of cab.
- Measure the distance between the rear of cab and the exhaust stack outlet.
- Verify clearance specs for new parts.
- Use 4" x 4" x 3/8" angle iron to fabricate the brackets. 12" length preferred, but no shorter than 8"

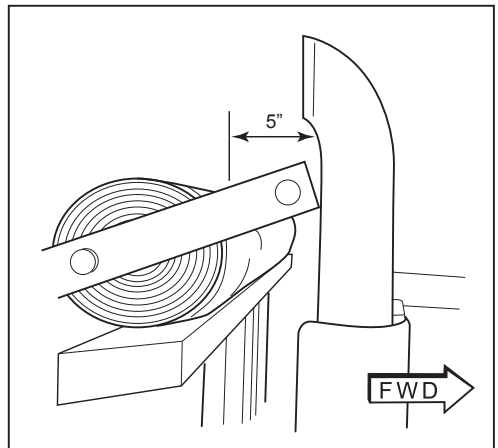
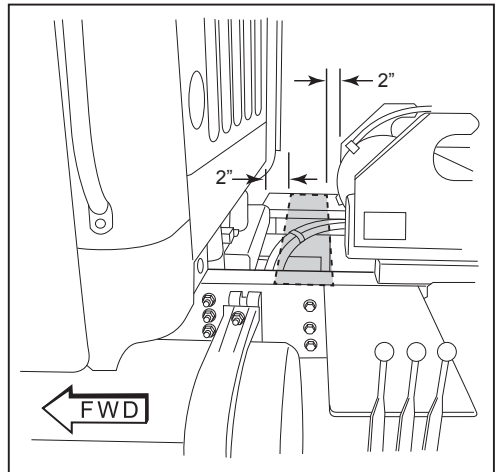
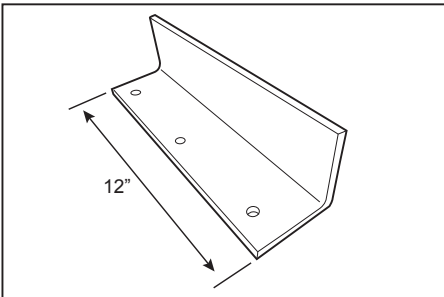

- e. Fabricate brackets for Driver Side and Passenger Side as needed to fit. Notch around existing hardware or utilize existing fasteners locations if possible.
 - f. Drill holes in frame and brackets as needed.
- IMPORTANT: Brackets must be fastened to frame using at least (2) 5/8" or (3) 1/2" Grade 8 fasteners.**
- g. Paint underside of brackets before mounting.
 - h. Treat drilled frame holes with rust preventer.

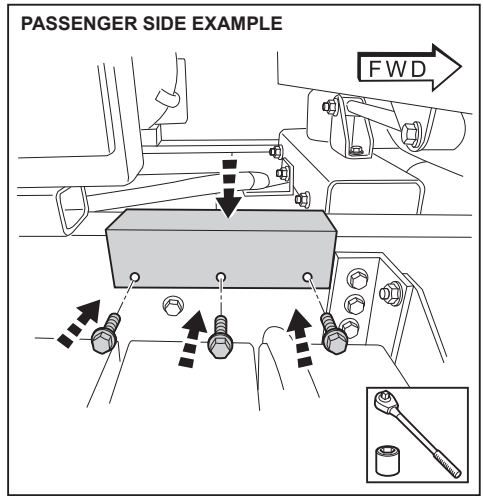
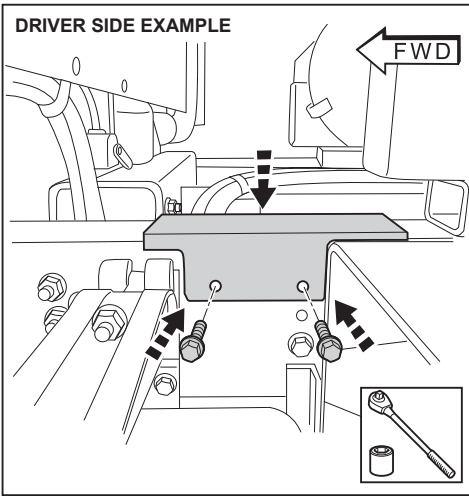

2. PREPARE GANTRY

- a. Lay gantry tower on ground.
- a. Position cross support at top of gantry.
- c. Attach cross support with (8) 5/16" x 2 3/4" bolts and Nyloc nuts.

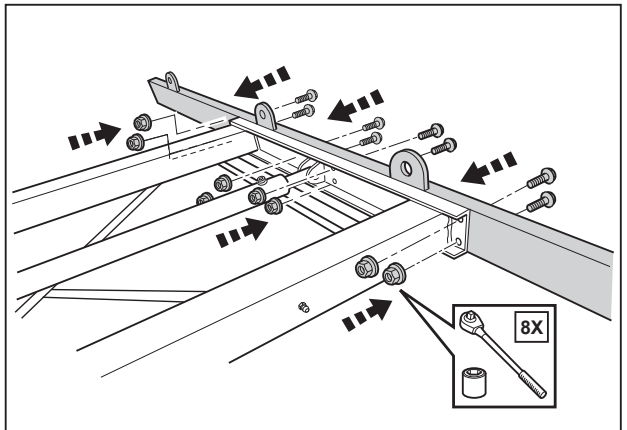

3) INSTALL GANTRY TO VEHICLE

NOTE: A lift hoist recommended.

- a. Secure lifting strap around top channel of gantry to prevent the cylinder from pulling apart.
- b. Lift gantry tower into position.

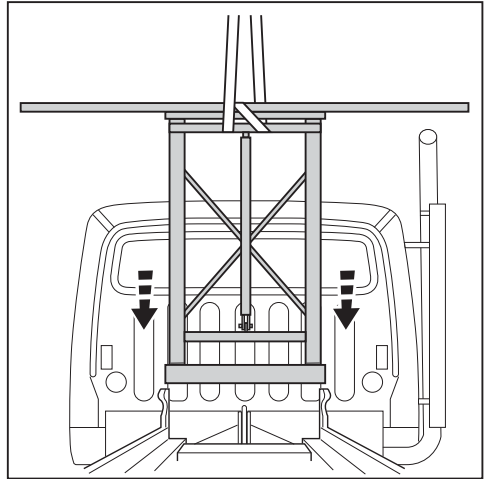

IMPORTANT: Check all position measurements to be sure gantry is centered, square with frame and proper clearances are all accounted for.

- c. Weld gantry to mount plates on both sides.

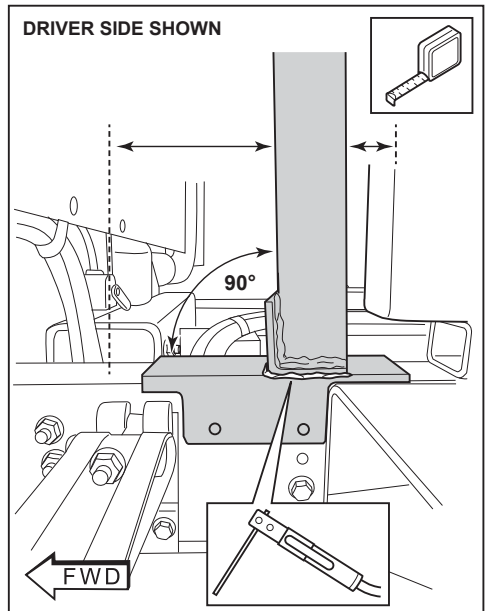

4) GANTRY ANGLE SUPPORTS

- Prep two (2) 12" lengths of 2"x 2" x 1/4" (or similar) angle iron.
- Position the supports between the mounting brackets and the gantry tower at an angle that will provide fore and aft support. Cut supports to fit as needed.
- Weld the supports into place on both sides of the vehicle.
- Paint all finished bracket surfaces.

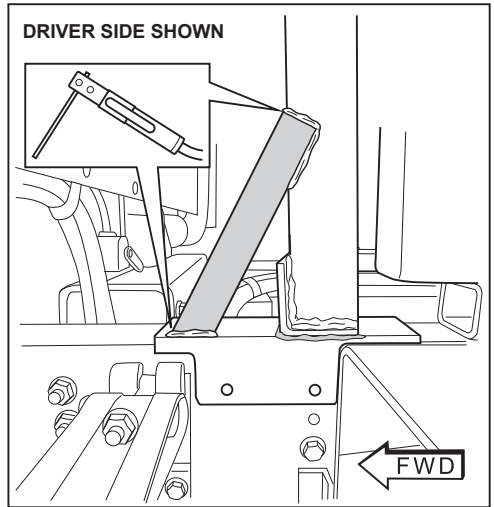

5. PIVOT MOUNTS

A secure framework is needed to bolt the guides and mounts. Use the 4" x 3" x 1/4" angle iron provided.

Begin by determining the proper locations based on these measurements:

- Measure container area front to back and determine halfway point. Mark locations on each side.
- Examine vehicle at this point and determine best mounting options. Extra bracket supports may need to be fabricated.
- IMPORTANT: Mounting framework should be 100" apart at outside vertical surface on the angle iron from left to right.**

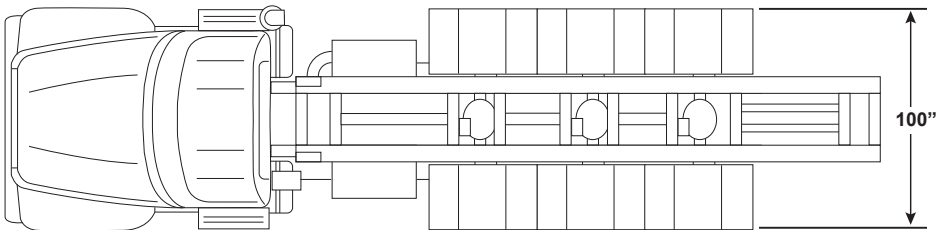
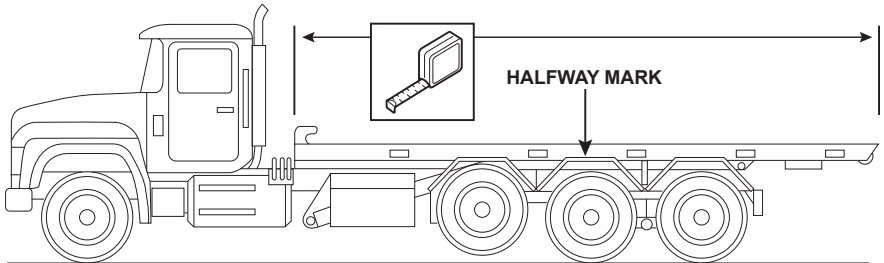

- d. Pivot Arch Mount Bracket requires 32" of clearance at base.
- e. Measure half that distance (16") forward from center marks on vehicle (this will be the leading edge of the arch bracket).
- f. Determine if the Mount Brackets can be attached at this location. IF NOT, find the closest forward location that will allow a minimum of 32" clearance for the Pivot Arch.

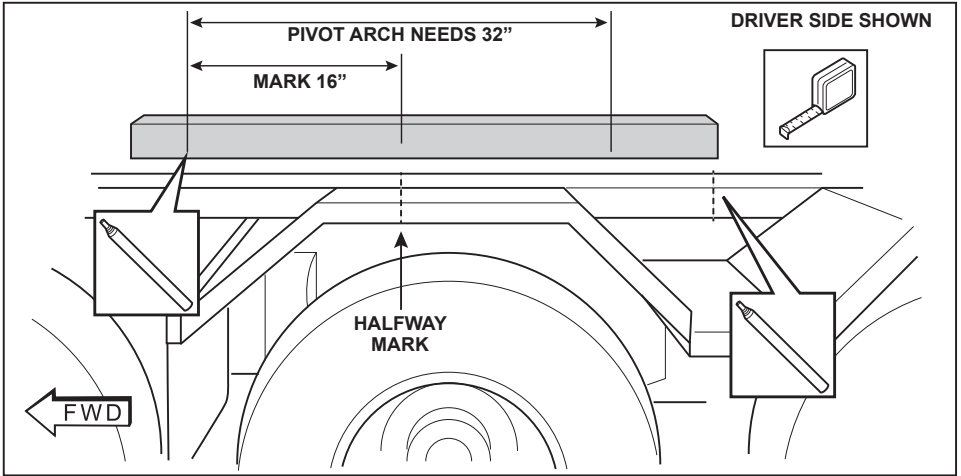

- g. Mark bracket mounting location on vehicle. Verify the 100" distance requirement from side to side.
NOTE: Extra support may be needed at the bracket. Fabricate as required.
IMPORTANT: Be sure to allow enough clearance for bottom of container.

h. Weld the 4" x 3" angle iron to the vehicle. **NOTE: Mount angle iron 3" vert. x 4" horiz.**

i. REPEAT ON OPPOSITE SIDE OF VEHICLE.

j. Paint all new bracket surfaces.

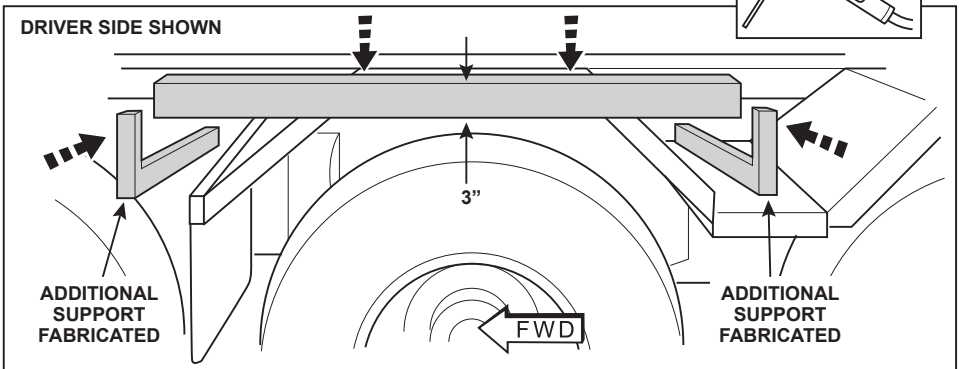

6. PIVOT INSTALLATION

- Position the arch bracket onto the angle iron so that center is aligned with earlier measurements
- Be sure top inside edge of arch bracket is flush with top of new angle iron
- Mark and drill rear-most hole from arch bracket. Bolt arch into position with $1/2"$ x $1 1/2"$ bolt and nut.
- Reposition the arch bracket and mark and drill (4) remaining holes

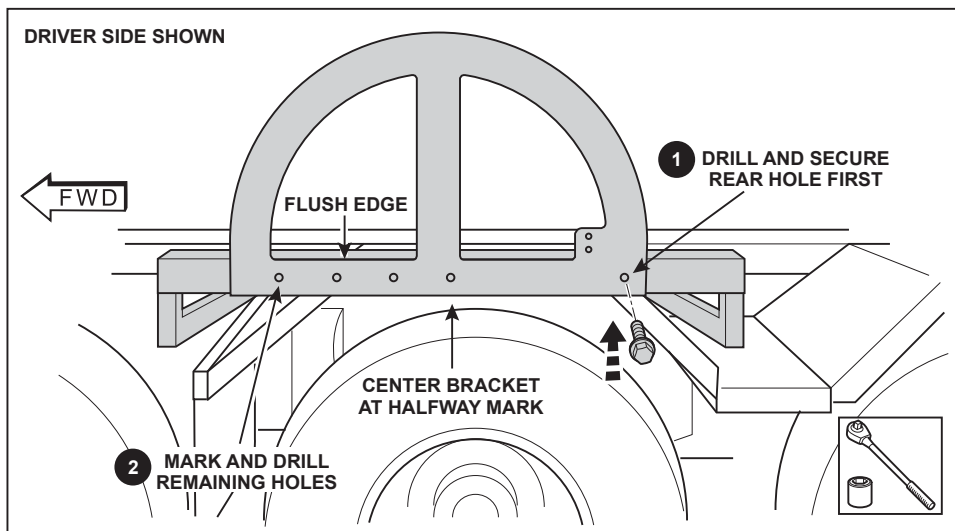

- Place arm pivot bracket into position and secure both parts to angle iron with $1/2"$ x $2 1/4"$ bolts and nuts.
- REPEAT ON PASSENGER SIDE OF VEHICLE.

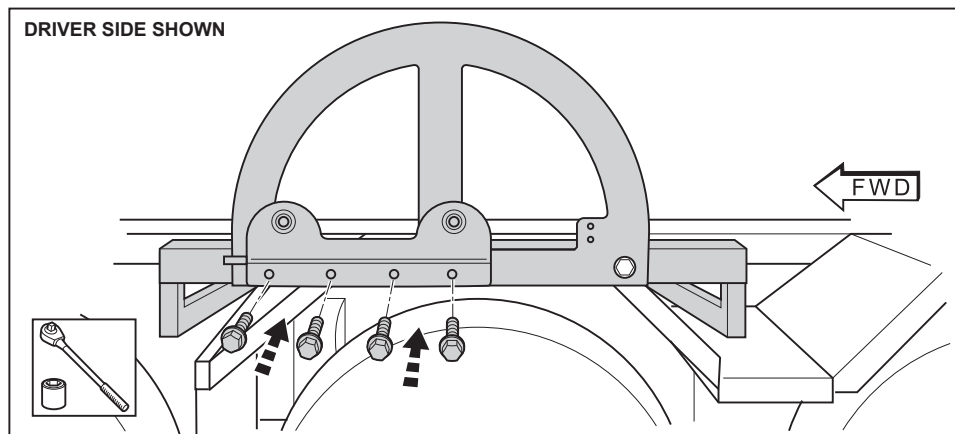

7. HYDRAULIC INSTALLATION

IMPORTANT: Hoses should be routed and installed to ensure no chafing or wear will occur. Hoses must not come in direct contact with any moving components on the truck or trailer frame.

- a. Locate a suitable position for the mounting bracket that will hold the Flow Divider Valves.
A cross member between the frame rails is recommended. **Fabricate a cross member if necessary.**
- b. Drill and mount the Flow Divider Valve bracket. Paint all new metal.
- c. Install all fittings to the Flow Divider Valves then mount the valves to the bracket with **5/16" x 3/4" bolts and nuts.**

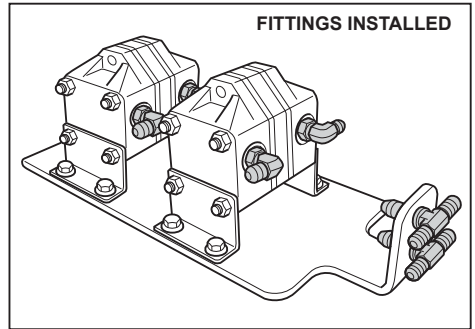
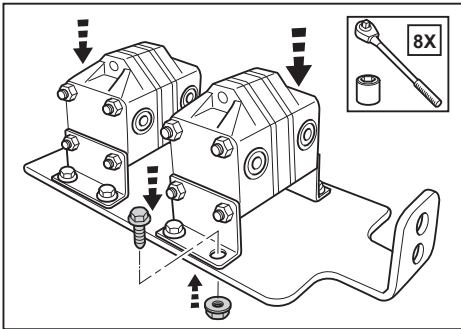

- d. Mount the bracket with valves in position at the cross member. **Be sure to maintain proper clearance.**

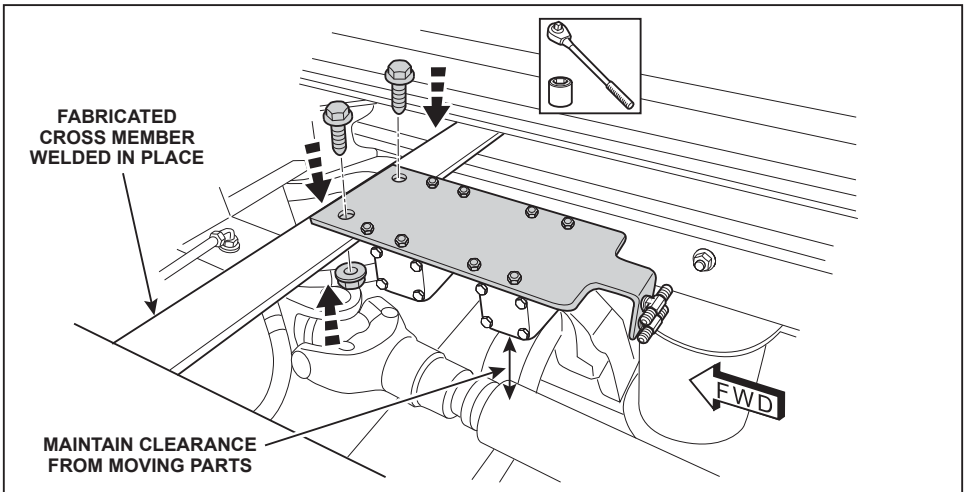

e. Locate a suitable position for the mounting bracket that will hold the Spool Valve. This should be in parallel with the existing Hoist Valve Controls.

f. A Priority Flow Valve will be mounted near this location also.

g. Fabricate mounting brackets for the Spool Valve and Priority Flow Valve (example shown).

h. Weld the new brackets into position.

NOTE: Allow area on the bracket for the control label.

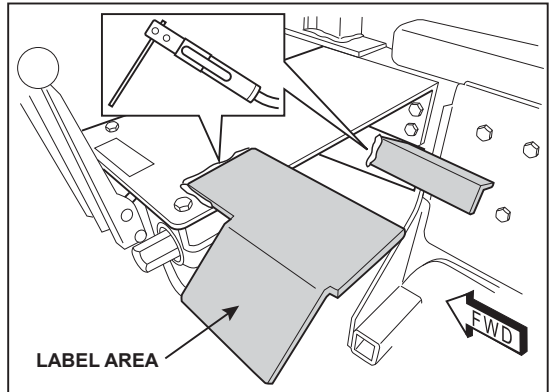

i. Drill mounting holes. Paint all new metal.

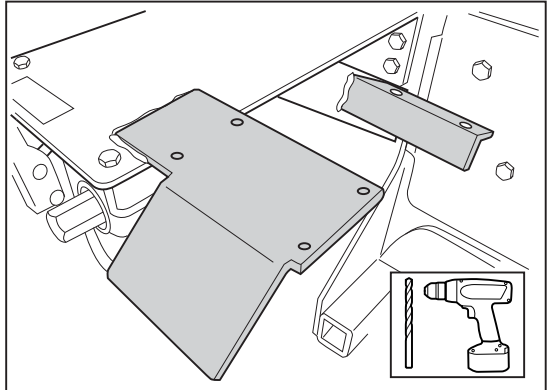

j. Mount the Spool Valve and Priority Flow Valve to the new brackets. **1/4" bolts and nuts recommended.**

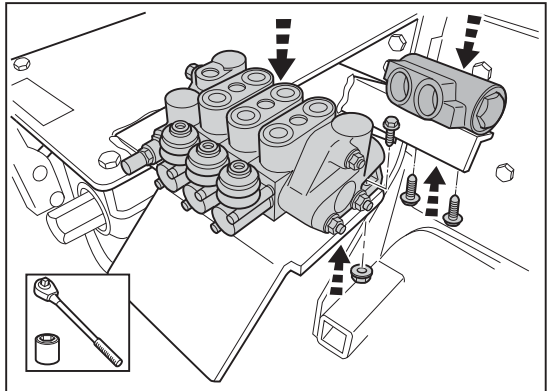

8. HYDRAULIC INSTALLATION DIAGRAM

- a. Route hoses from control valves to Flow Divider Valves.
- b. Route hoses from control valves to Gantry.
- c. Route hoses from Control Valve Assy to Reservoir.
- d. Route hose from original vehicle fluid pressure supply to Diverter Valve.

NOTE: If existing control valves will be used in place of the Spool Valve provided, a Needle Valve must be positioned as indicated to control the speed of the arms.

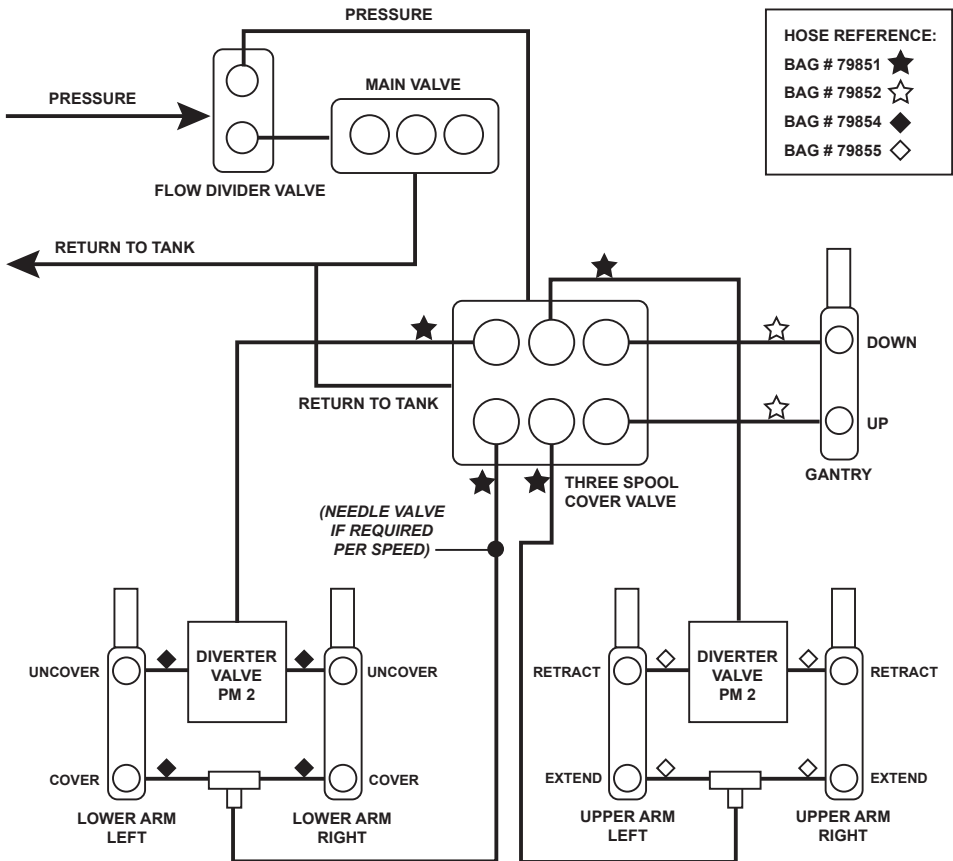
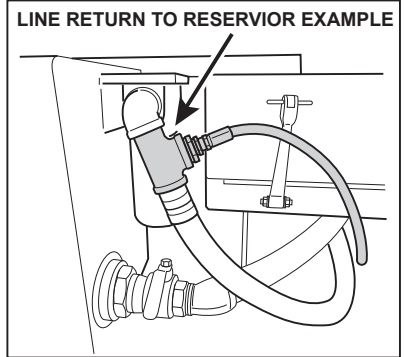

9. MOUNT ROLL TARP ASSEMBLY TO GANTRY

IMPORTANT: Install the Roll Tarp Assembly so that the hex end of the torsion tube axle is positioned at the driver side of the vehicle.

- a. Lift the Roll Tarp assembly into position on the top of the Gantry Cross Support. Secure in place with ratchet straps.

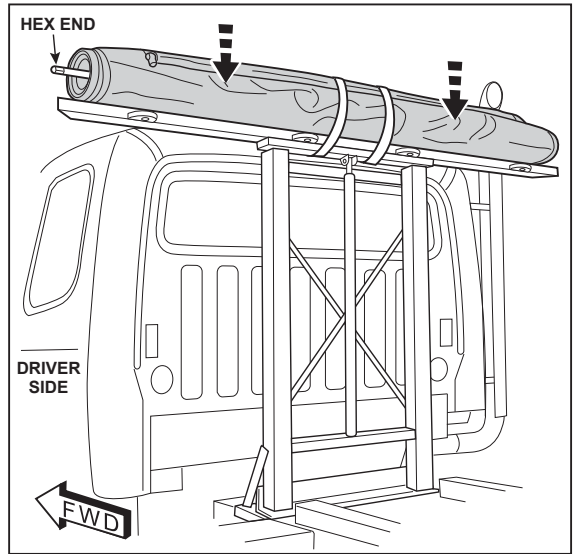
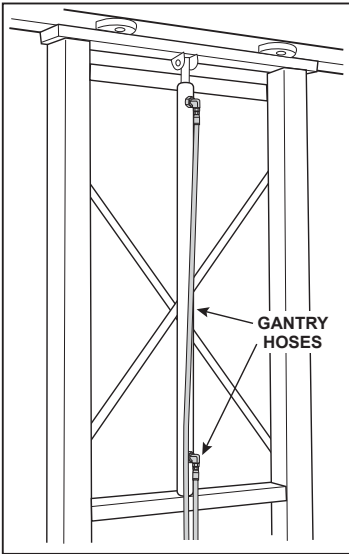

NOTE: Visually align the torsion axle with the center of the gantry front to back.

- b. Mount ends of hold down bar into cross bar on both sides with $1/2'' \times 1\ 1/4''$ bolts and lock washers.

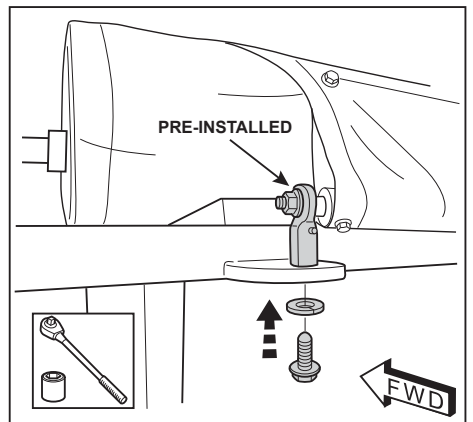
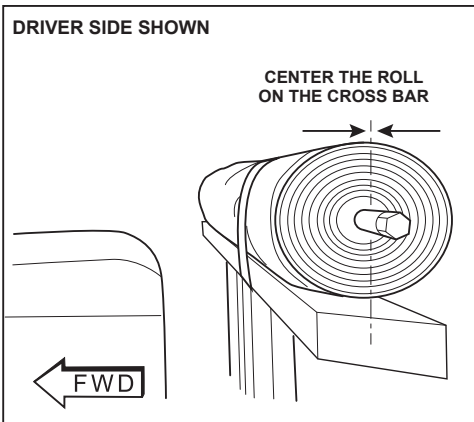

10. LIFT CYLINDERS

- a. Mount left and right lift cylinders onto pivot brackets **3/4" x 2 3/4" bolts and nuts**.
- b. Route and install all hoses to cylinder fittings.
- c. Secure hoses with hose clamps and zip ties.

DRIVER SIDE SHOWN

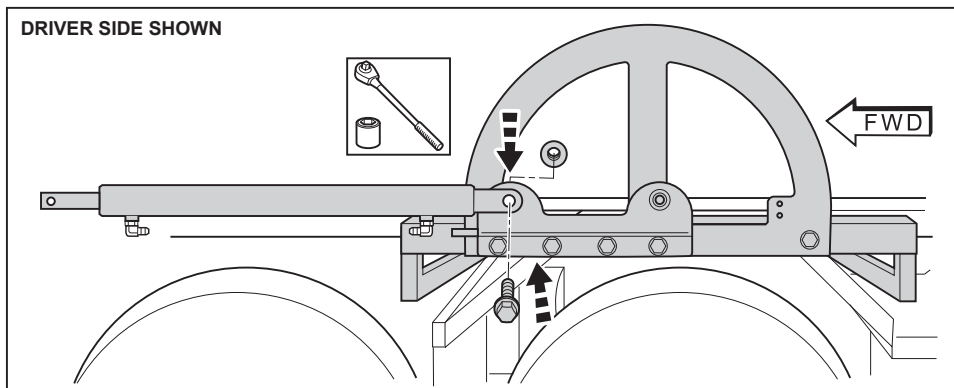

MAIN ARM HOSE ROUTING

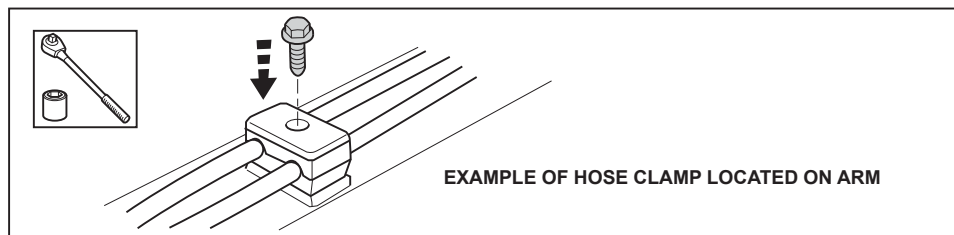
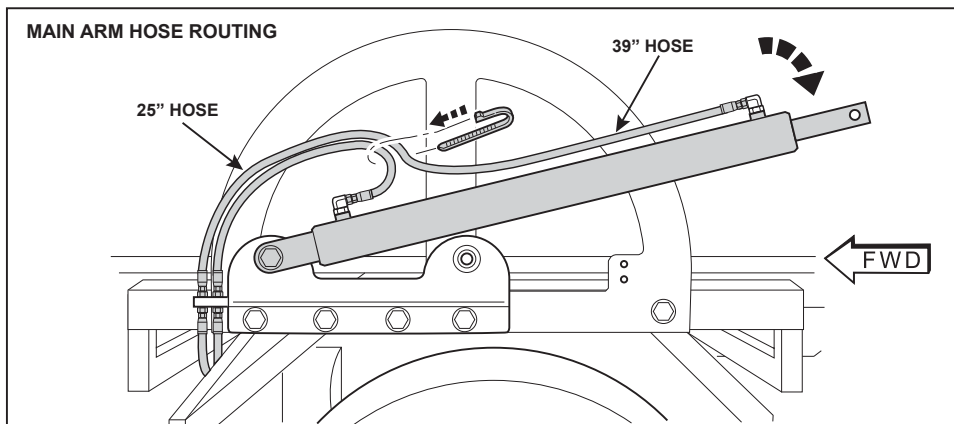

11. ARMS AND TRACKING BARS

- a. Measure the distance between the lower arm mount at the pivot bracket and the torsion axle of the roll tarp. Make sure it is even on both sides and record the measurement (X).

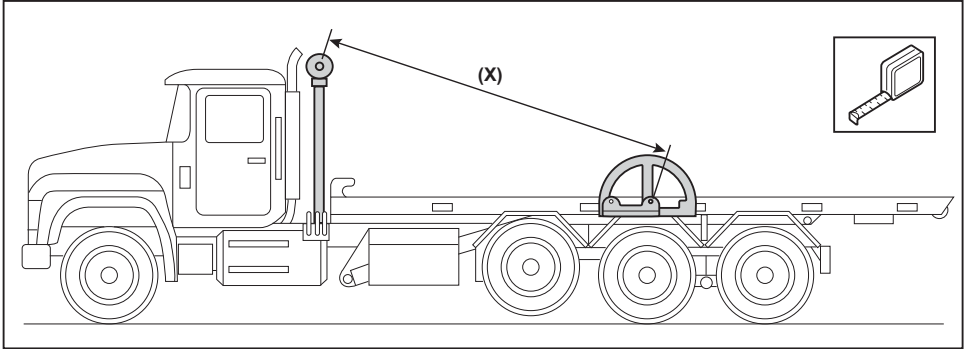

NOTE: Upper arm has a steel block end with two mounting holes. The upper hole is for the Tracking Bar and the lower hole is for the Torsion Tube.

- b. Place the lower arm tube on work surface
- c. Slide the upper arm tube into the lower arm tube so that the total distance from top Torsion Tube hole to bottom pivot hole is at the measurement determined above (X). Mark the upper arm at this length.

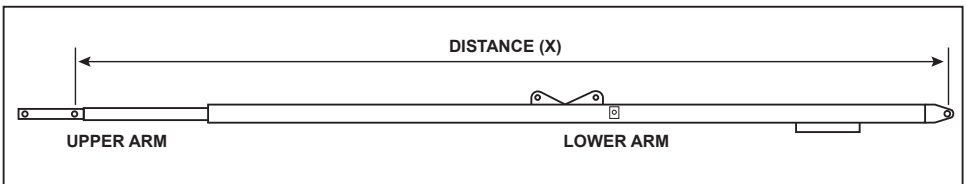
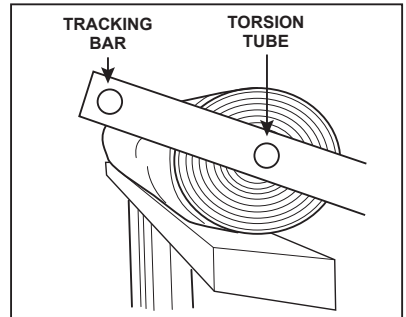

- d. Pin the Arm Extension Cylinder in position on the arm and use this to determine the location of the upper arm mounting plates. **NOTE:** Be sure the cylinder piston is fully seated.

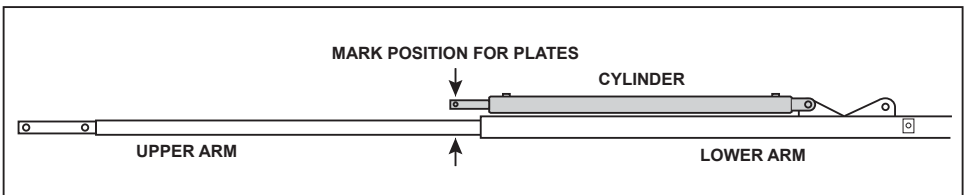

e. Clamp upper mounting plates into place using the cylinder as a guide. Weld two new cylinder mount plates onto upper arm.

f. Remove cylinder. Paint all new metal

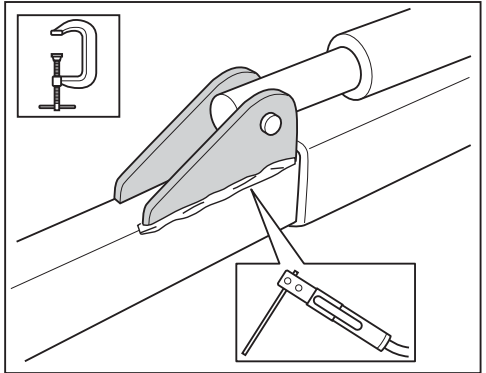

g. Install nylon guide blocks on inside of lower arms with $3/8" \times 1 \frac{1}{2}"$ bolts

h. REPEAT STEPS FOR OPPOSITE ARM

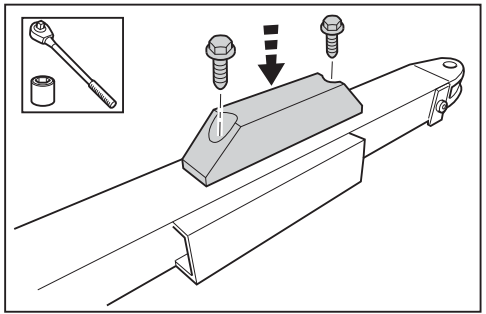

12. ARM AND EXTEND/RETRACT CYLINDER INSTALLATION

a. Mount the lower arm onto the pivot bracket with $3/4" \times 2 \frac{3}{4}"$ bolt and nut.
NOTE: Use awl to align holes.

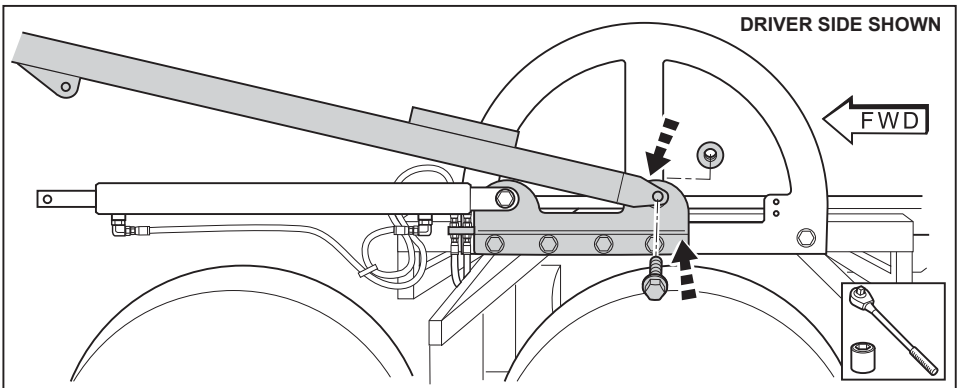

b. Slide upper arm tube into lower arm tube.

c. Install the Arm Extension Cylinder with a 1/2" x 2 1/4" bolt and nut support with strap.

NOTE: Do not pin cylinder to upper arm at this time.

d. **REPEAT ON PASSENGER SIDE OF VEHICLE**

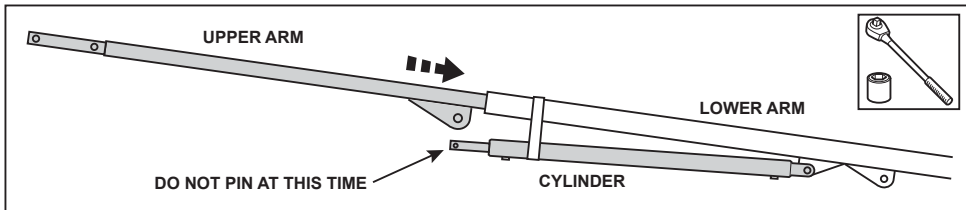
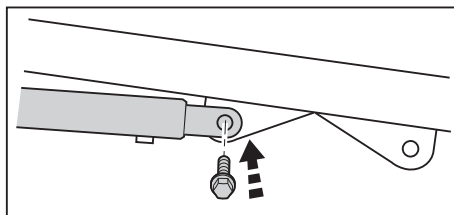

e. Route and install all hoses. See diagram on page 12.

f. Secure hoses hold-down brackets and zip ties INSIDE of arms.

g. **REPEAT ON PASSENGER SIDE OF VEHICLE.**

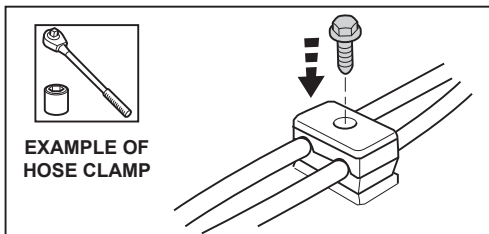
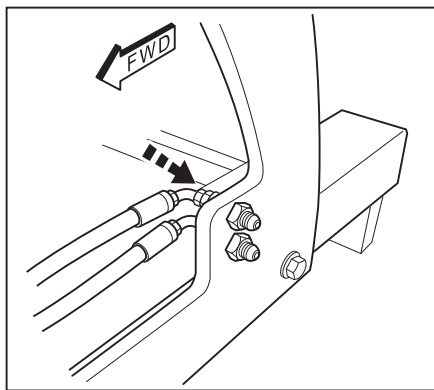

EXAMPLE OF HOSE CLAMP

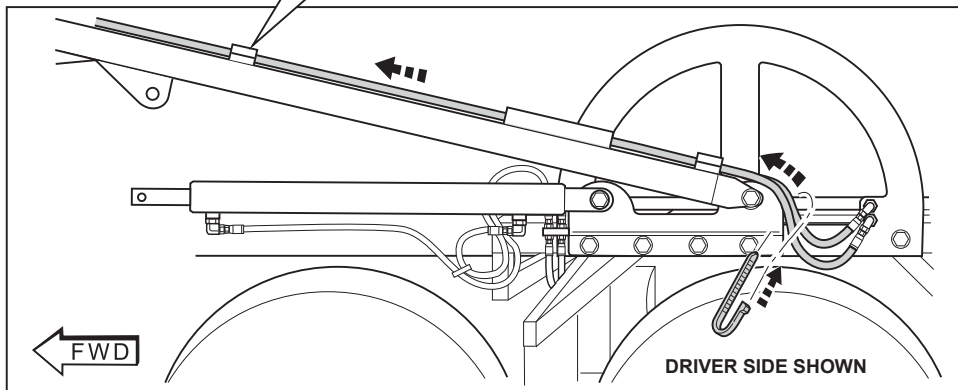

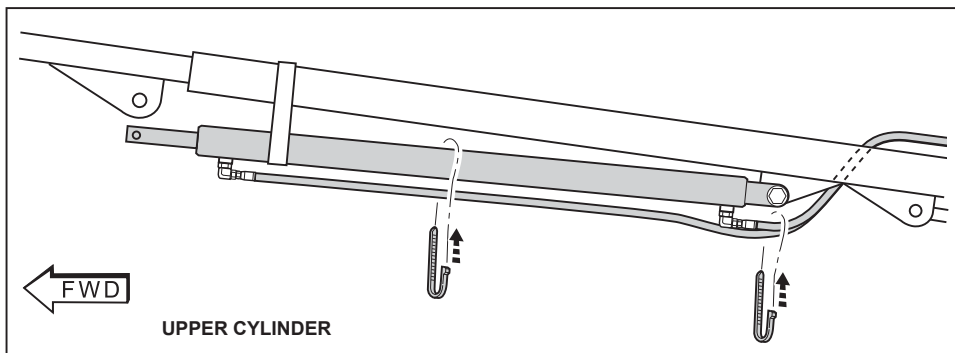

IMPORTANT: Bleed the system at this time to test that cylinders are operating properly.

h. Install upper pivot on Lift Cylinder and secure with 1/2" x 2" Clevis Pin.

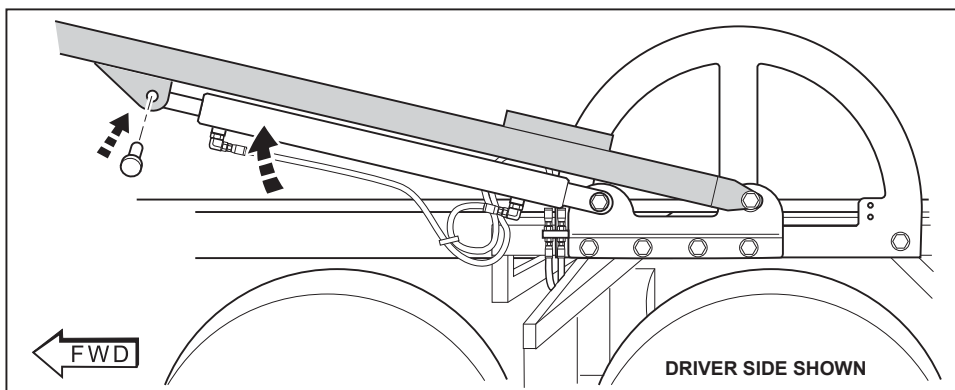

i. Install upper pivot of the Arm Extend/Retract cylinder with 1/2" x 2" Clevis Pin.

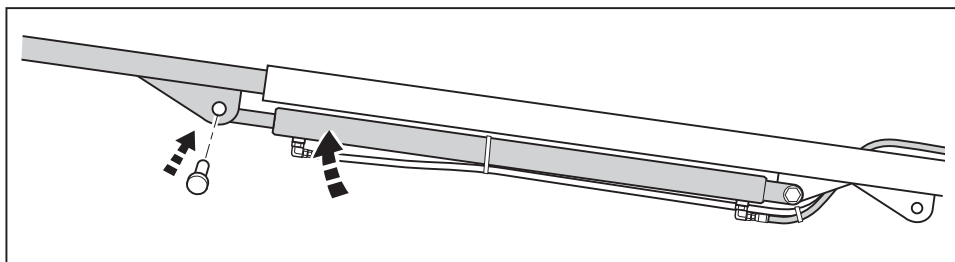

13. WIND ROLL TARP TORSION TUBE AXLE



CAUTION: Follow precautions to avoid injury or damage to parts

Roll Tarp Torsion Tube must be preloaded (wound) before final assembly

Be sure to stand on a stable, flat platform with both feet flat on surface

Keep area under the Torsion Tube and gantry clear of all personnel

Be sure to position body within 18" of the hex end of the Torsion Tube to avoid over reaching or leaning in too far.

Use a body harness when standing on a raised platform higher than four feet from the ground.

- a. Place the upper arm over the hex end of the Torsion Tube. Using a six-point socket and a 1/2" drive breaker bar, wind the Torsion Tube **(8) turns counterclockwise** to preload.

DO NOT USE AN ADJUSTABLE WRENCH, OPEN ENDED WRENCH OR RATCHET HANDLE.

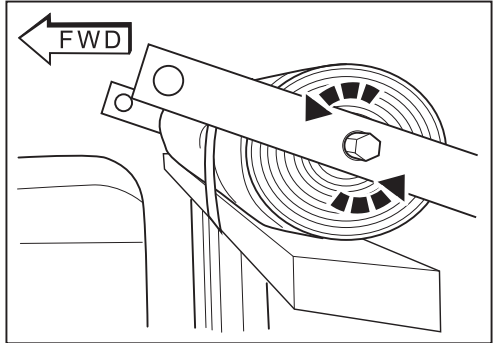

- b. Lock the Torsion Tube into position with **5/16" x 2 1/2" bolt and lock nut after winding.**
- c. Install the top tracking bar (ahead of the tarp) into the upper arm with the hex end on the driver side and lock into position with **5/16" x 2 1/2" bolt and lock nut.**
- d. Install torsion tube end and tracking bar end into upper arm on passenger side and secure with **5/16" x 2 1/2" bolt and lock nut.**

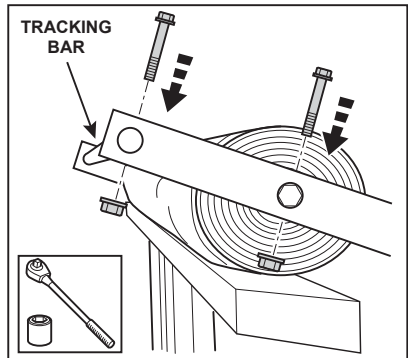

- Check all routings, fittings and components.
- Cycle and operate system to check for proper functionality
- Operate system to fully covered position

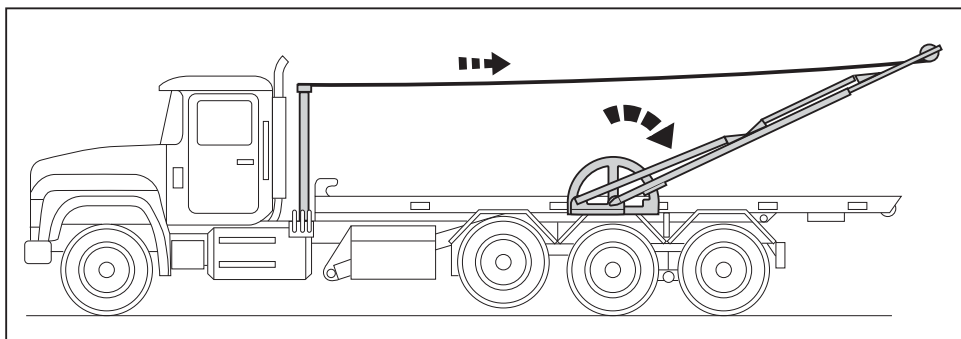

15. INSTALL SAFETY STOPS

Safety Stops can be welded on the arches in a position that best suits the needs of the customer. They should allow the arms to come below the size of the smallest container being hauled to allow the tarp system to fully cover the container.

- Support the arms evenly on both sides at the back of the vehicle. Be sure the arms are level.

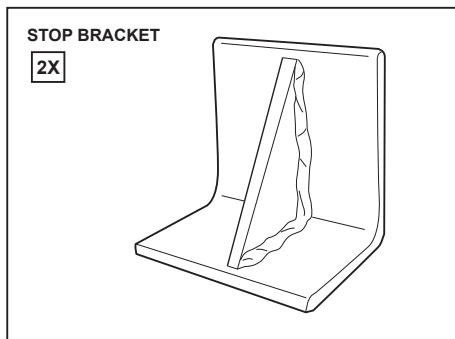
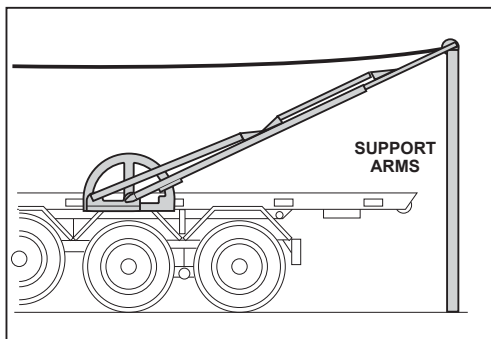

- c. Mark arm stop position on arch brackets on both sides

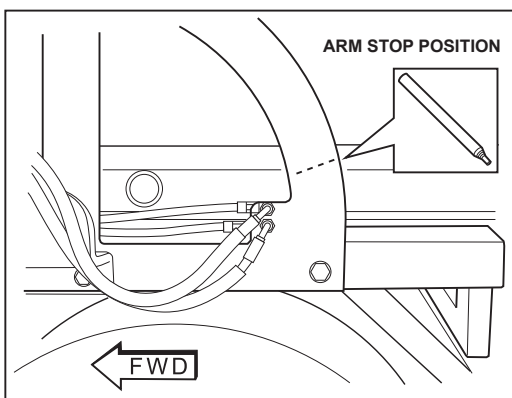

- d. Prep and weld into position on both sides

- e. Paint all surfaces

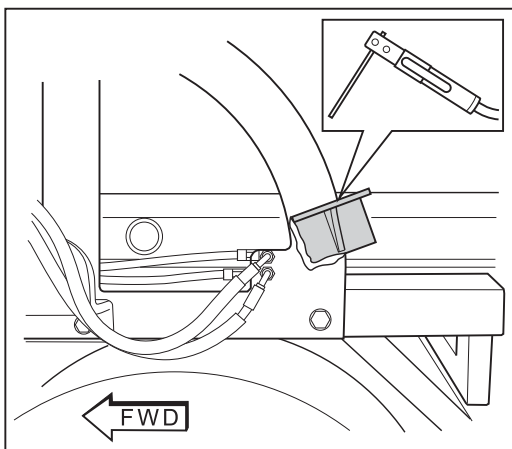

Roll-Rite LLC and its entire staff would like to thank you for your business and offer you not only the finest product in our industry, but the best customer service as well. Please visit our Website at www.rollrite.com to find a complete set of parts diagrams.

Please contact us if you have any questions or issues

Phone: 800- 297-9905 or 860-309-6523
email: info@rollrite.com or tylerb@rollrite.com
Fax: 888-827-7329



Automated Covering Systems

OPERATION

IMPORTANT: Be sure the system is free of any obstructions or damage before operating.

Lever 1 – Operates Lift Cylinder to Open and Close Cover

Lever 2 – Operates Extend/Retract Arm Function

Lever 3 – Operates Gantry Raise and Lower

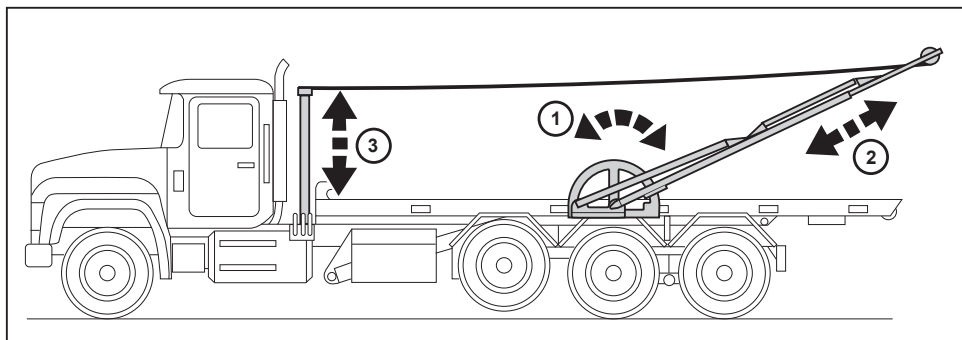
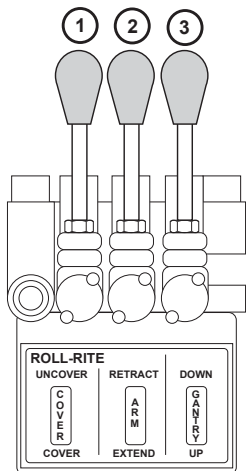

MAINTENANCE

- Grease the system at fittings (A) as needed to ensure smooth operation.
- Inspect Tarp regularly for damage and wear.
- Be sure Tarp Material is retracting evenly on both sides to avoid wear or damage.

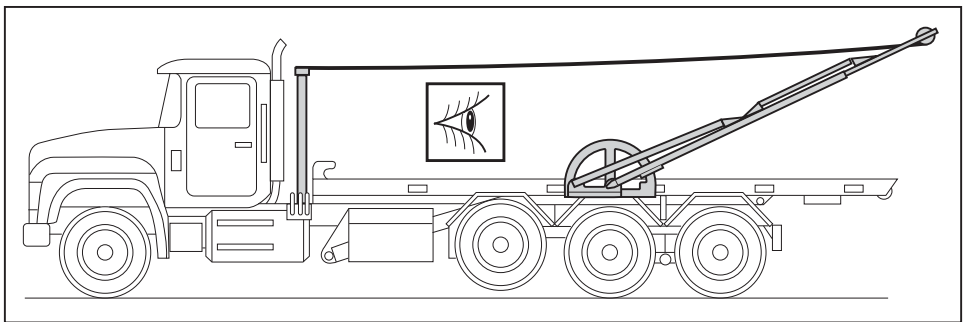
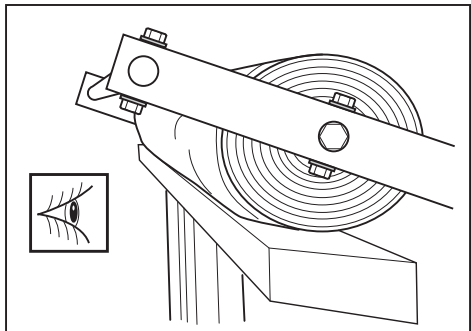
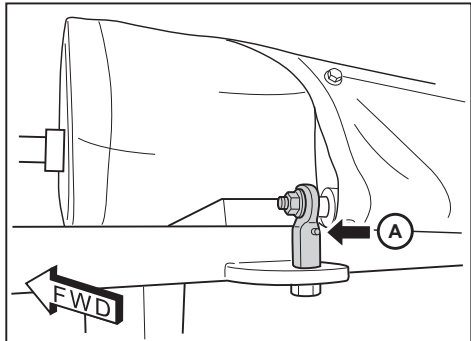
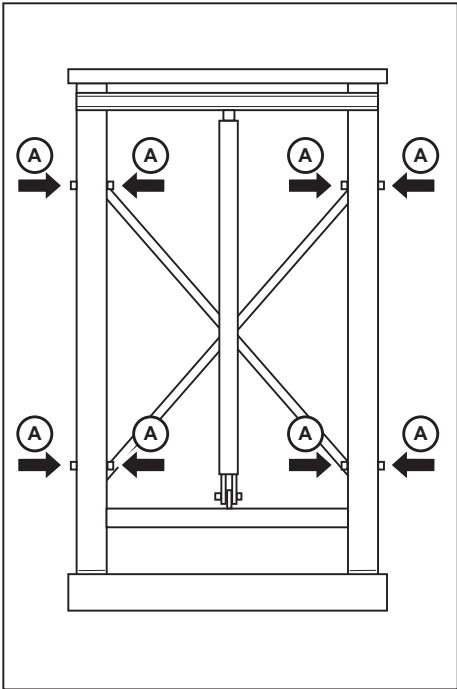

MAINTENANCE

CHANGING THE TARP AND TUBE ASSEMBLY

TOOLS

1. 3/4" socket and breaker bar
2. 3/4" wrench
3. 1/2" wrench
4. 1/2" socket and ratchet
5. 3/8" socket
6. 10' ratchet strap
7. 5/16" hex wrench

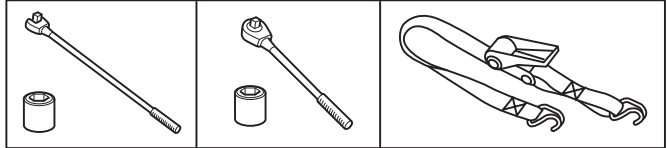

CAUTION: Follow precautions to avoid injury or damage to parts

Be sure to stand on a stable, flat platform with both feet flat on surface

Keep area under the Torsion Tube and gantry clear of all personnel

Be sure to position body within 18" of the hex end of the Torsion Tube to avoid over reaching or leaning in too far.

Use a body harness when standing on a raised platform higher than four feet from the ground.

Be sure to perform this operation when tarp system is in the UNCOVERED position.

Position system so that tube assembly is off of rubber pads enough to remove tarp. Approx. 6"

If the system does not have a tracking bar or to be more cautious, put ratchet strap between upper arm cylinder plates to hold the arms from popping off tube assembly shaft.

- a. Remove the 5/16" bolts from the end of each arm (the ones holding the tube assembly shaft) With these removed, the spring tension will unwind.
- b. Remove the 1/2" bolts holding the rod ends to the gantry hold down bar plates
- c. Remove the 1/4" bolts holding the tarp to the hold down bar.

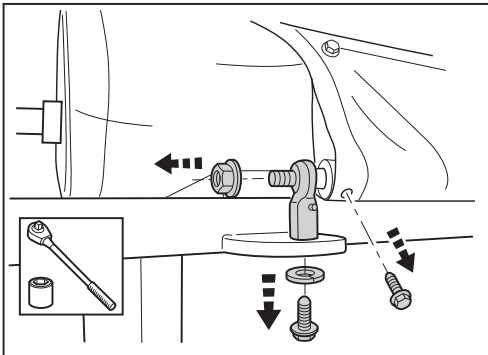
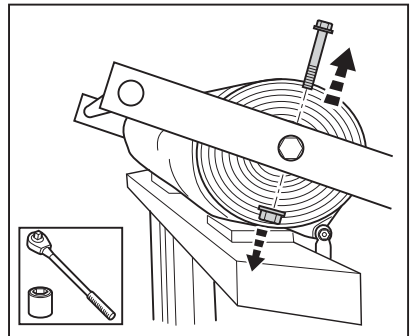

MAINTENANCE

- d. Remove 1/2" nut from one side of hold down bar and remove the rod end. You will then be able to slide the hold down bar out of the tarp pocket.
- e. You can now unwind the tarp (clockwise from driver's side) either by pulling the tarp or using 3/4" socket and breaker bar or 3/4" wrench.
- f. Once the tarp is all the way off the roll the six (6) 5/16" screws are visible.
- g. Remove these screws to remove the tarp.

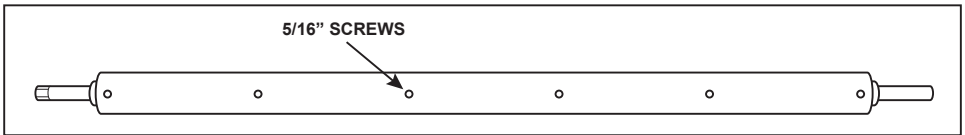
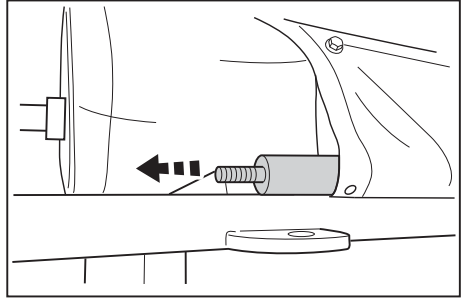

NOTE: If the tube assembly is damaged, you can remove it from the arms at this time. It may be necessary to loosen the ratchet strap and remove the 5/16 bolt from one end of the tracking bar to allow one arm to be moved out to make it easier.

To install the new tube assembly be sure the 1" shaft is in both arms and the tracking bar and ratchet (if applicable) are installed or tight.

- a. Install the tarp using the (6) 5/16" screws. Wind the tarp back up **OVER THE TOP COUNTER** CLOCKWISE, from driver's side, until all the tarp is rolled up.

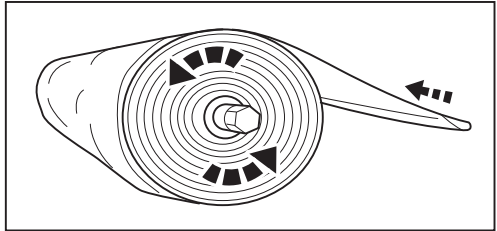

- b. Slide the hold down bar back though and reinstall the rod end with the 1/2" nut.
- c. Install the 1/4" bolts to secure the tarp to the hold down bar.
- d. Install the 1/2" bolts to secure hold down bar/rod ends to the gantry hold down bar plates.

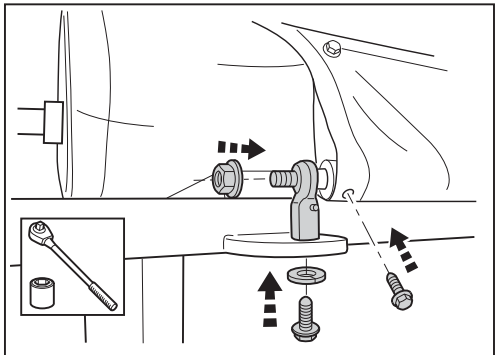

MAINTENANCE

- e. Now you can preload the spring by winding the shaft using 3/4" socket and breaker bar or 3/4" wrench 8 to 9 turns COUNTER CLOCKWISE.
- f. Before letting go of tension install 5/16 bolts in the end of each arm to hold tube assembly in place.
- g. Be sure all nuts and bolts are tight and ratchet strap is removed.
- h. Run the system a few times to insure proper functioning.

